

Please read and save these instructions. Read through this owner's manual carefully before using product. Protect yourself and others by observing all safety information, warnings, and cautions. Failure to comply with instructions could result in personal injury and/or damage to product or property. Please retain instructions for future reference.



AIR HYDRAULIC 20 TON SHOP PRESS

FOR CUSTOMER SERVICE

Technical Question?

CALL 1-866-458-2472
customerservice@oem-tools.com

UNPACKING

After unpacking unit, inspect carefully for any damage that may have occurred during transit. Check for loose, missing, or damaged parts. If any damage is observed, a shipping damage claim must be filed with carrier. DO NOT use the OEMTOOLS® 25087/45087 Air Hydraulic 20 Ton Shop Press if broken, bent, cracked or damaged parts (including labels) are noted. Any Shop Press that appears damaged in any way, operates abnormally, or is missing parts should be removed from service immediately. If you suspect that the Shop Press was subjected to shock load (a load that was dropped suddenly, unexpectedly, etc.), immediately discontinue use until it has been checked by a factory authorized service center.



⚠ WARNING

The following safety information is provided as a guideline to help you operate your Shop Press under the safest possible conditions. Any tool or piece of equipment can be potentially dangerous to use when safety or safe handling instructions are not known or not followed. The following safety instructions are to provide the user with the information necessary for safe use and operation. Please read and retain these instructions for the continued safe use of your Shop Press. Failure to follow instructions listed below may result in serious injury. In addition, make certain that anyone who uses the equipment understands and follows these safety instructions as well.

Explanation of Safety Signal Words

⚠ WARNING: Indicates a potentially hazardous situation which, if not avoided, could result in death or serious injury.

⚠ CAUTION: Indicates a potentially hazardous situation which, if not avoided, may result in minor or moderate injury.

CAUTION: Used without the safety alert symbol indicates a potentially hazardous situation which, if not avoided, may result in property damage.

NOTES: Provide clarity and helpful information.

Thank you very much for choosing an OEMTOOLS® Product!

For future reference, please register your new tool at www.oem-tools.com and complete the owner's record below:

Model: _____ **Purchase Date:** _____

Save the receipt, warranty and these instructions. It is important that you read the entire manual to become familiar with this product before you begin using it. This product is designed for certain applications only. OEMTOOLS® cannot be responsible for issues arising from modification. We strongly recommend that this product is not modified and/or used for any application other than that for which it was designed. If you have any questions relative to a particular application, DO NOT use the product until you have first contacted customer service to determine if it can or should be performed on the product.

⚠ WARNING: This product can expose you to chemicals which are known to the State of California to cause cancer and birth defects or other reproductive harm. For more information go to www.P65Warnings.ca.gov.



AIR HYDRAULIC 20 TON SHOP PRESS

! IMPORTANT INSTRUCTIONS AND SAFETY RULES

1. Know your product. Read this manual carefully. Learn the product’s applications and limitations, as well as potential hazards specific to it. The use of this product is simple and straightforward if you follow the instructions. When operating this product, use common sense and only use this product for its intended purpose.
2. Maintain labels and nameplates on this product. These carry important information. If unreadable or missing, contact OEMTOOLS® for a replacement.
3. Maintain this product with care. Keep it dry and clean – and free from brake fluid, oil, and grease (if applicable).
4. Check for damage. Check your product regularly. If part of the product is damaged, it should be carefully inspected to make sure that it can perform its intended function correctly. If in doubt, the part should be repaired. Refer all servicing to a qualified technician. Consult your dealer for advice.
5. Check for misalignment or binding of moving parts, breakage of parts, and any other condition that may affect the product’s operation.
6. DO NOT use a damaged product. Tag damaged products “DO NOT USE” until repaired. If damaged, have the product serviced before using. Many accidents are caused by poorly maintained products.
7. Service must be performed only by qualified repair personnel. Service or maintenance performed by unqualified personnel could create a risk of injury.
8. When servicing a product, use only identical replacement parts. Use of unauthorized parts or failure to follow maintenance instructions could create a risk of injury.
9. Use only accessories that are recommended by the manufacturer for your model. Accessories that may be suitable for one product may become hazardous when used on another product.
10. Keep work area clean and well lit. Cluttered or dark work areas invite accidents.
11. Maintain a safe working environment. Keep the work area well lit. Make sure there is adequate surrounding workspace. Keep the work area free of obstructions, grease, oil, trash, and other debris. DO NOT use this product in a damp or wet location.
12. Keep children away. All children should be kept away from the work area. Never let a child handle this product without strict adult supervision.
13. Store this product out of the reach of children and untrained persons. This product may be dangerous in the hands of untrained users.
14. DO NOT operate this product if under the influence of alcohol or drugs. Read warning labels on prescriptions to determine if your judgment or reflexes are impaired while taking drugs. If there is any doubt, DO NOT attempt to operate.
15. Use safety equipment. Eye protection should be worn at all times when operating this product. Use ANSI approved safety glasses. Everyday eyeglasses are NOT safety glasses. Dust mask, non-skid safety shoes, hard hat or hearing protection should be used in appropriate conditions.
16. Wear proper apparel. Loose clothing, gloves, neck-ties, rings, bracelets or other jewelry may present a potential hazard when operating this product. Keep all apparel clear of the product.
17. DO NOT overreach. Keep proper footing and balance at all times when operating this product.
18. Keep away from flammables. DO NOT attempt to operate this product near flammable materials or combustibles. Failure to comply may cause serious injury or death.
19. Avoid accidental fire and/or explosion. DO NOT smoke near engine fuel and battery components.
20. We believe the information contained herein to be reliable. However, general technical information is given by us without charge and the user shall employ such information at their own discretion and risk. We assume no responsibility for results or damages incurred from the use of such information in whole or in part. Always refer to specific instructions and technical information supplied by vehicle manufacturer.
21. The manufacturer declines any and all responsibility for property damage or injury if said damage is the result of unskillful handling by the operator or of failure to observe the basic safety rules set forth in the instruction manual.
22. The warnings, precautions, and instructions discussed in this manual cannot cover all possible conditions and situations that may occur. The operator must understand that common sense and caution are factors which cannot be built into this product, but must be supplied by the operator.

PRODUCT DESCRIPTION

The OEMTOOLS® 25087/45087 20 Ton Air Hydraulic Shop Press utilizes an air/hydraulic power system with double speed pump that delivers up to 20 tons of pressing force. The pressing ram head can be operated with either the hydraulic hand pump lever or the pneumatic pump to remove or assemble press fit components.

PRODUCT SPECIFICATIONS

Capacity	20 Tons
Pump Design	Double Speed Pump
Ram Travel	7-1/4"
Frame Width	29"
Frame Height	59-5/8"
Overall Height	70-3/8"
Total Weight	247 Lb.





AIR HYDRAULIC 20 TON SHOP PRESS

SPECIFIC SAFETY INSTRUCTIONS AND WARNINGS

Thoroughly read and understand all instructions in this product manual before using this product. Failure to follow all instructions listed below may result in death, serious personal injury and/or property damage. Like most shop equipment, there is potential danger when operating this press. Accidents are often caused by lack of familiarity or failure to pay attention. Use this press with caution to decrease the risk of operator injury. If normal safety precautions are overlooked or ignored, serious personal injury may occur.

▲WARNING:

- DO NOT use a damaged or malfunctioning press.
- DO NOT exceed the rated capacity. Never apply excessive force to a workpiece and always use the pressure gauge to accurately determine the applied load. Exceeding rated press capacity can damage the press, shatter a workpiece, or launch a press pin (causing a severe impact injury). When the press has reached its maximum pressure or the pump lever becomes stiff to operate, the press has reached its limit. Never use a cheater pipe for extra leverage.
- DO NOT stand directly in front of a loaded press and never leave loaded press unattended.
- Applying pressure to parts with this press can cause them to spring out and strike you or bystanders with deadly force. Verify that bystanders are a safe distance away from the press when it is being operated.
- When a part is pressed free, a workpiece may shift suddenly or fall from the press (possibly crushing a foot or leg). Use a catch basket and support long or awkward work pieces with stands or chains.
- NEVER apply pressure to round objects, springs, or elastic items. Applying pressure to unstable objects can cause the object to eject, causing an impact injury.
- Being hit by an ejected workpiece or press tooling can cause severe impact injury or death. When using the press, stand out of the way of any possible projectile path. Never press with rods or pins that are long enough to shift off-center and kick out under a load. Never stack rods and spacers to create an extended press pin. If pressing must occur with an extended press pin, the pin must be fastened with a safety chain or the press pin must be enclosed in a safety cage to eliminate a projectile hazard.
- NEVER use this press to unload spring-loaded assemblies without also using the correct spring caging tool or jig.
- NEVER attempt to re-align a workpiece while it is under pressure. Relieve hydraulic pressure, and start pressing operations over if a workpiece or press pin has moved or become misaligned. If a workpiece becomes misaligned during pressing operations, it may slip out of the press and cause a severe impact injury.
- ALWAYS relieve hydraulic pressure if you suspect the workpiece is in a bind, or structural failure is imminent.
- DO NOT work under the press when it is loaded.

CAUTION:

- Some workpieces cannot withstand the force of pressing and can explode, causing impact injury. Other workpieces have hidden retaining rings, shoulders, pins, and/or welds, or are integral and cannot be pressed apart. Before using this press, make sure you understand how a component is built and pressed apart.
- Use only on a hard, level and flat surface capable of bearing the combined weight of the Shop Press, the operator and any tools being used.

PERSONAL SAFETY

Always wear appropriate safety gear including heavy duty work gloves, ANSI approved safety goggles and steel toe boots during use.

ASSEMBLY

▲WARNING: The hydraulic power unit provided with this press is intended to be used as an integral part of this press and not as a stand-alone jacking device separate of the press. Never use the hydraulic power unit provided with this press for any purpose other than that for which it is intended.

Use the parts diagram in this manual as reference for assembly if necessary. Lay all parts and assemblies out in front of you before beginning.

It is advised that you have assistance with standing up and balancing the parts during assembly.

NOTE: DO NOT fully tighten bolts unless instructed to do so at that step of the assembly.

- Use Flat Washer (12), Lock Washer (13), Nut (14), Bolt (27), Flat Washer (20), Lock Washer (21), Nut (22) and Bolt (23) to connect Support Bar (28), Base (19) and Connecting Bar (24) with Post (18).
- With both Upper Beams located back to back, slide the Mounting Plate (5) onto the lower edge of both and carefully assemble to the post using Bolt (7), Flat Washer (9), Lock Washer (10) and Nut (11) to connect Upper Beam (8) to Post. Use caution not to allow the mounting plate to fall free from the upper beams.
- Connect Ram (3), Upper Round Nut (4) and Lower Round Nut (6) to Mounting Plate (5).
- Use Flat Washer (12) and Bolt (29) to connect Pump (30) with Post (18). Then connect the Oil Hose (32) with Ram (3).
- Connect Pressure Gauge (1), Nylon Washer (2) to Ram (3). Tighten the nut to prevent oil leaking. The required tightening force is 20-25 Nm.
- Insert Support Pins (17) into the holes on the Post (18).
- Use Flat Washer (12), Lock Washer (13), Nut (14) and Bolt (25) to connect the 2 Work Beams (16) using the Bushing (26) between them.
- Lower the assembly onto the Support Pins (17). Then, insert Clips (31) into the groove on the Support Pins.
- Tighten all fasteners.



AIR HYDRAULIC 20 TON SHOP PRESS

OPERATION

CAUTION: Before each use, inspect the general condition of the Shop Press. Check for oil leaks, press operation, and loose components. If a problem occurs, have the problem corrected before further use.

Before First Use:

1. Pour a teaspoon of good quality air tool lubricant into the air supply inlet of the control valve, connect to an air supply and operate for 3 seconds to evenly distribute lubricant.
2. Open the pump release valve by using the handle and turning it counter-clockwise. Pump several strokes to eliminate any air from the system. Close valve by turning clockwise once air is properly removed.

Before use, make sure the ram is fully retracted, then loosen the breath nut on the pump and tighten the nut again.

1. Set the Support Pins (17) to desired height, and then lower the Work Beam (16). Ensure Work Beam is fully rested on the Support Pins.
2. Place Press Blocks (15) on the Work Beam (16) as needed. The Press Blocks must be used as a pair.
3. Place workpiece on Press Blocks (15), using every precaution necessary to ensure your safety and prevent workpiece damage. Position workpiece in a manner which will not allow it to inadvertently fall from blocks.
4. Close the pump release valve by turning it clockwise.
5. Initiate the Ram by depressing the Air Valve and allowing the Ram Saddle to lower until close to the workpiece. Release the air valve stop the ram.
6. Align ram and workpiece to ensure center-loading.
7. Apply load to workpiece by pumping the handle. DO NOT overload workpiece.

NOTE: DO NOT continue to pump after ram is fully extended.

8. Stabilize workpiece in a manner which will not allow it to inadvertently fall from the blocks once the load is removed, then turn release valve counter-clockwise to retract the ram and remove workpiece. DO NOT turn the release valve counter-clockwise more than 1 full turn.

CARE AND MAINTENANCE

Before each use, inspect press for damage. DO NOT use if bent, broken, cracked, leaking or otherwise damaged components are noted. Periodically, lightly oil all moving parts, including the pump piston and ram. Check ram and pump piston for signs of rust on a regular basis. Clean as needed with a lint free, oil saturated cloth. If press will not be in use for some time, pour a teaspoon of good quality air tool lubricant into the air supply inlet of the control valve, connect to an air supply and operate for 3 seconds to evenly distribute lubricant.

ADDING/CHANGING OIL

NOTE: Premium hydraulic jack oil or equivalent is recommended. Avoid mixing different types of fluid and NEVER use brake fluid, turbine oil, transmission fluid, motor oil or glycerin. Improper fluid can cause premature failure of the ram and the potential for sudden and immediate loss of pressure.

1. Remove the Air Venting Screw (P14) on the pump and fill with hydraulic jack oil as necessary.
2. Replace the Air Venting Screw.
3. Purge air as described in BEFORE FIRST USE above.

TROUBLESHOOTING

⚠WARNING: Use caution when troubleshooting a malfunctioning press. Stay well clear of the supported load. Completely resolve all problems before use. If the press is malfunctioning, have a qualified technician inspect and repair the press before use.

After the press is repaired: test it carefully without a load by raising it and lowering it fully, checking for proper operation.

Symptom	Possible Cause	Corrective Action
Ram will not press load	<ul style="list-style-type: none"> • Release valve not tightly closed • Faulty/Loose couplers • Oil level in pump is low • Release valve not fully closed 	<ul style="list-style-type: none"> • Ensure release valve tightly closed • Remedy overload condition • Replace/ Tighten couplers • Fill and bleed system • Tighten release valve
Ram bleeds off after press operation	<ul style="list-style-type: none"> • Release valve not tightly closed • Ram malfunction 	<ul style="list-style-type: none"> • Ensure release valve tightly closed • Contact OEMTOOLS®
Ram will not retract after unloading	<ul style="list-style-type: none"> • Reservoir overfilled • Linkage binding 	<ul style="list-style-type: none"> • Drain fluid to proper level • Clean and lubricate moving parts
Poor pressing performance	<ul style="list-style-type: none"> • Fluid level low • Air trapped in system 	<ul style="list-style-type: none"> • Ensure proper fluid level • Bleed air from system
Ram will not extend to full extension	<ul style="list-style-type: none"> • Fluid level too low 	<ul style="list-style-type: none"> • Ensure proper fluid level
Oil leak from ram	<ul style="list-style-type: none"> • Ram malfunction 	<ul style="list-style-type: none"> • Contact OEMTOOLS®

DISPOSAL

At the end of the useful life of the press, dispose of the components according to all local, state, and federal regulations.



AIR HYDRAULIC 20 TON SHOP PRESS

PARTS DIAGRAM - ASSEMBLY

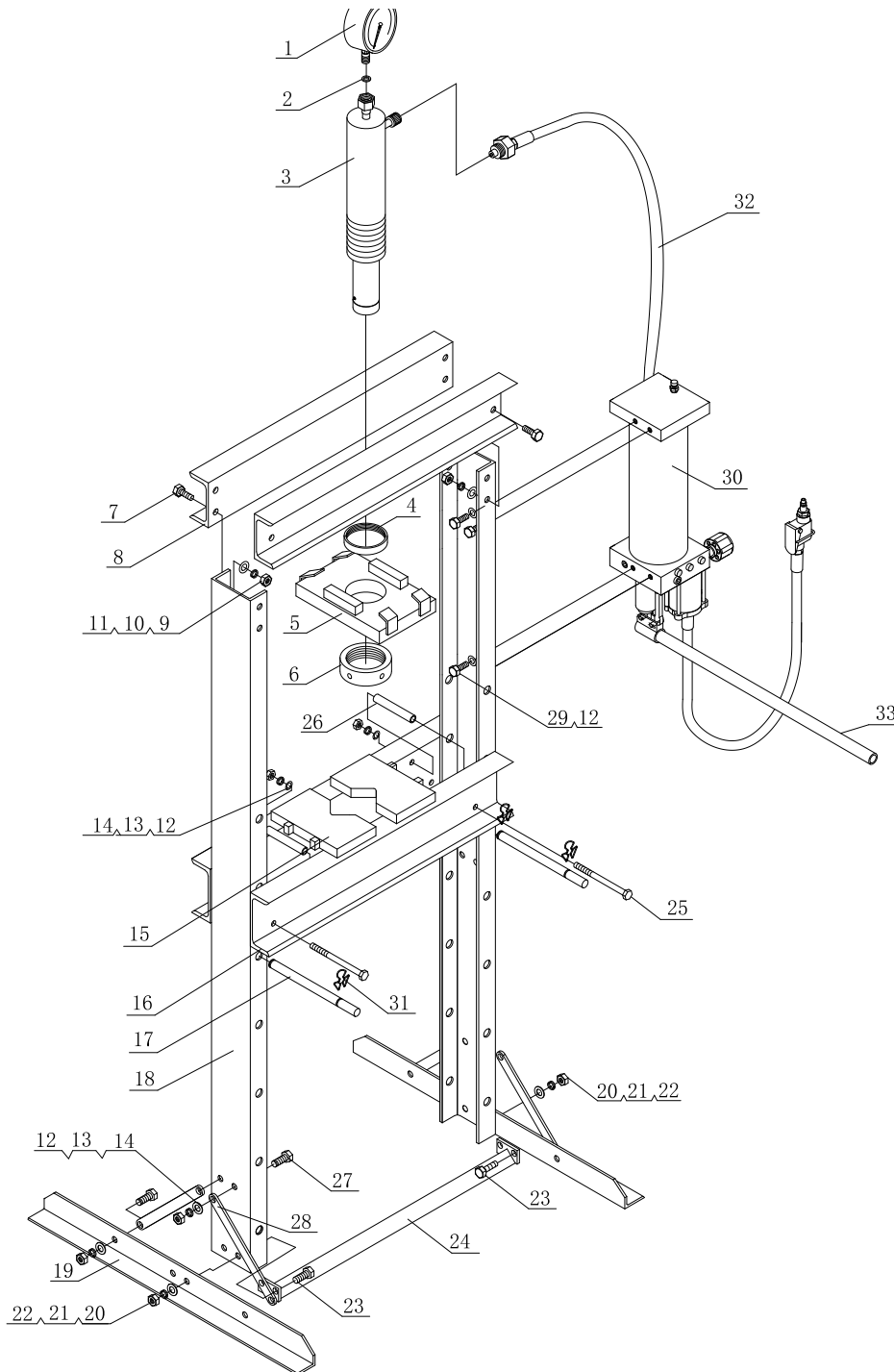

PARTS LIST - ASSEMBLY

Figure	Description	Qty.
1	20T Gauge	1
2	Nylon Ring	1
3	Ram	1
4	Upper Round Nut	1
5	Mounting Plate	1
6	Lower Round Nut	1
7	Bolt	8
8	Upper Beam	2
9	Flat Washer	8
10	Lock Washer	8
11	Nut	8
12	Flat Washer	16
13	Lock Washer	12
14	Nut	12
15	Press Block	2
16	Work Beam	2
17	Support Pin	2
18	Post	2
19	Base	2
20	Flat Washer	4
21	Lock Washer	4
22	Nut	4
23	Bolt	4
24	Connecting Bar	1
25	Bolt	4
26	Bushing	4
27	Bolt	8
28	Support Bar	4
29	Bolt	4
30	Pump	1
31	Clip	4
32	Oil Hose	1
33	Handle	1



AIR HYDRAULIC 20 TON SHOP PRESS

PARTS DIAGRAM - PUMP

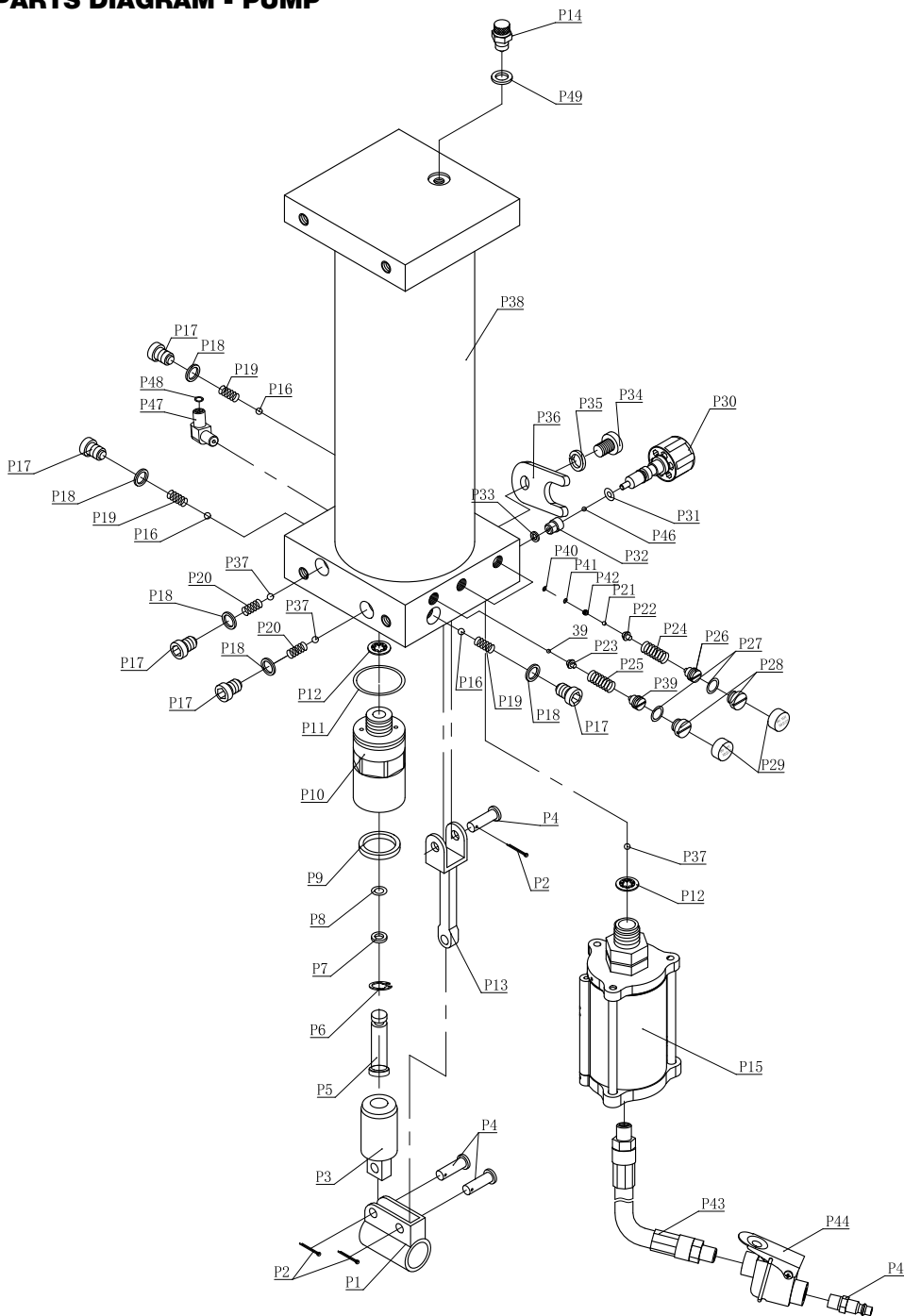
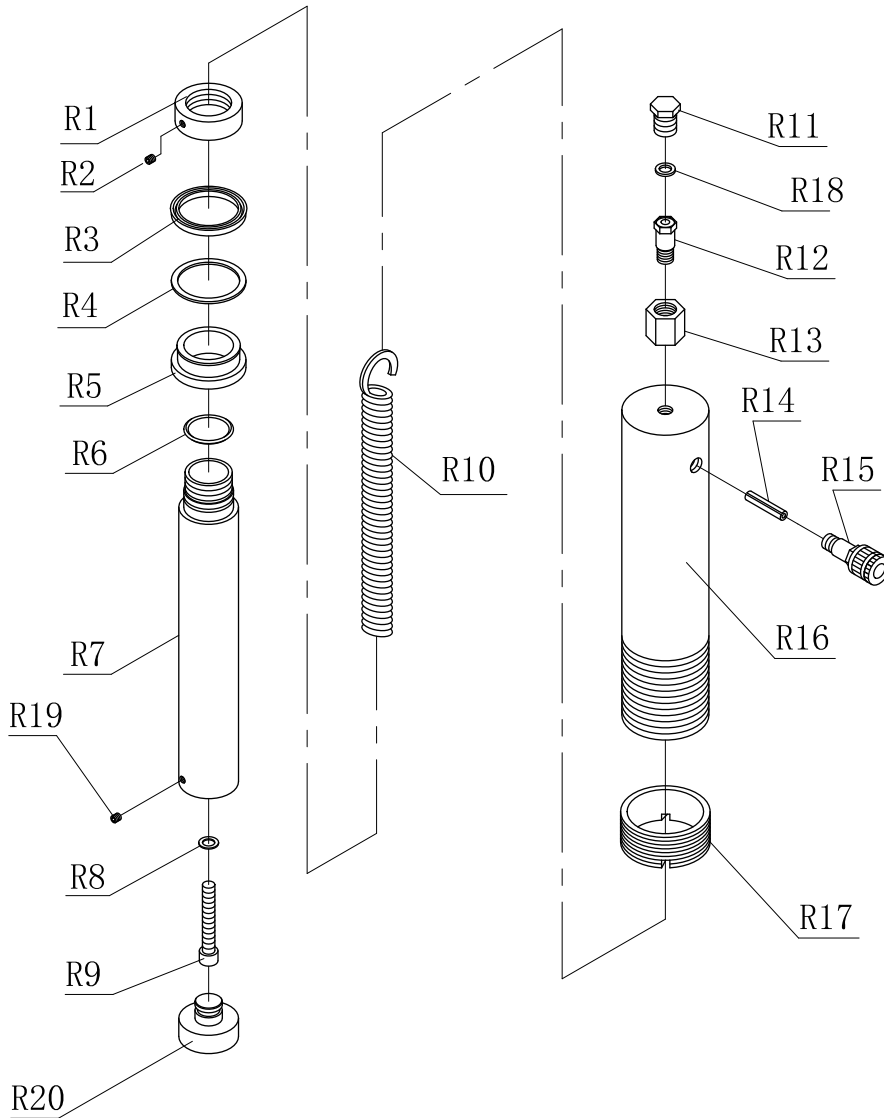

Figure	Description	Qty.
P1	Handle Socket	1
P2	Cotter Pin	2
P3	Big Piston	1
P4	Pin	3
P5	Small Piston	1
P6	Retaining Ring	1
P7	Seal Ring	1
P8	O Ring	1
P9	U Ring	1
P10	Pump Seat	1
P11	O Ring	1
P12	Copper Ring	2
P13	Connector	1
P14	Air Venting Screw	1
P15	Air Pump	1
P16	Steel Ball	3
P17	Screw	5
P18	Copper Ring	5
P19	Spring	3
P20	Spring	2
P21	Valve Ball	2
P22	Ball Cup	2
P23	Ball Cup	1
P24	Spring	2
P25	Spring	1
P26	Screw	2
P27	O Ring	3
P28	Plug Screw	3
P29	Plastic Cap	3
P30	Release Valve	1
P31	O Ring	1
P32	Valve Base	1
P33	Washer	1
P34	Screw	1
P35	Lock Washer	1
P36	U Limit	1
P37	Steel Ball	3
P38	Pump	1
P39	Screw	1
P40	Copper Ring	2
P41	Seal Ring	2
P42	Screw	2
P43	Air Inlet Hose	1
P44	Air Valve	1
P45	Hose Fitting	1
P46	Steel Ball	2
P47	Joint	1
P48	O Ring	1
P49	Nylon Ring	1



AIR HYDRAULIC 20 TON SHOP PRESS

PARTS DIAGRAM - RAM



PARTS LIST - RAM

Figure	Description	Qty.
R1	Round Nut	1
R2	Screw	1
R3	U Ring	1
R4	Seal Ring	1
R5	Piston	1
R6	O Ring	1
R7	Piston Rod	1
R8	Copper Ring	1
R9	Screw	1
R10	Spring	1
R11	Plug Screw	1
R12	Gauge Fitting	1
R13	Nut	1
R14	Spring Pin	1
R15	Joint Screw	1
R16	Ram	1
R17	Spacing Ring	1
R18	Nylon Ring	1
R19	Screw	1
R20	Saddle	1



AIR HYDRAULIC 20 TON SHOP PRESS

WE STAND BEHIND OUR TOOLS. OEMTOOLS® 1 YEAR WARRANTY

If within 1 year from the date of purchase of this OEMTOOLS product, you find any defect in material or workmanship, through normal usage, return it to the place of purchase or to OEMTOOLS® for repair or replacement at our discretion. In order to obtain this service, send your tool and proof of purchase (transportation pre-paid) to:

OEMTOOLS® Q.A. Dept., 3580 E. Raines Road #3, Memphis, TN 38118.

We will not be responsible for lost or damaged goods during transportation; please insure your package. If our inspection verifies the defect, we will repair or replace the product, or we may elect to refund the purchase price if we cannot readily and quickly provide you with a replacement. We will return repaired products at our expense, but if we determine there is no defect, or that the defect resulted from causes not within the scope of our warranty, then you must bear the cost of returning the product.

OEMTOOLS® does not provide warranty for products labeled other than OEM® or OEMTOOLS®. OEMTOOLS® will not provide any warranty for products subjected to abnormal use. Abnormal use includes (but is not limited to) abuse, accident, alteration, neglect, and unauthorized or unreasonable use or repairs. This warranty does not cover bits, blades, files, batteries, or calibration. We recommend that you maintain your tools and sharpen or replace blades, bits, files, and batteries as necessary. OEMTOOLS® reserves the right to make any changes in construction or design at any time without any obligation in incorporating such changes to tools or equipment previously sold.

OEMTOOLS® makes every effort to ensure that its products meet high quality and durability standards, and warrants to the original purchaser that this product is free from defects in materials and workmanship. This warranty does not apply to damage due directly or indirectly to misuse, abuse, negligence or accidents, repairs or alterations outside our facilities, criminal activity, improper installation, normal wear and tear, or to lack of maintenance.

OEMTOOLS® is not responsible for damaged shipments or shortages resulting from carrier mishandling. Notify your carrier's office immediately to file a claim. Keep damaged goods and containers for inspection until advised by the carrier as to disposal.

We shall in no event be liable for death, injuries to persons or property, or for incidental, contingent, special or consequential damages arising from the use of our product. Some states do not allow the exclusion or limitation of incidental or consequential damages, so the above limitation of exclusion may not apply to you. THIS WARRANTY IS EXPRESSLY IN LIEU OF ALL OTHER WARRANTIES, EXPRESS OR IMPLIED, INCLUDING THE WARRANTIES OF MERCHANTABILITY AND FITNESS. This warranty gives you specific legal rights, and you may also have other rights, which vary from state to state.

Please contact us at customerservice@oem-tools.com or call us at 901-370-1101 for additional information or questions.

Thank you for your purchase.

CONTACT US

3580 E. Raines Road, Suite 3, Memphis, TN 38118
Tel: 1-866-458-2472
www.oem-tools.com