

Please read and save these instructions. Read through this owner's manual carefully before using product. Protect yourself and others by observing all safety information, warnings, and cautions. Failure to comply with instructions could result in personal injury and/or damage to product or property. Please retain instructions for future reference.



SIDEKICK CREEPER STOOL

FOR CUSTOMER SERVICE

Technical Question?

CALL 1-866-458-2472
customerservice@oem-tools.com

UNPACKING

After unpacking the unit, inspect carefully for any damage that may have occurred during transit. Check for loose, missing, or damaged parts. If any damage is observed, a shipping damage claim must be filed with the carrier. DO NOT use the OEMTOOLS® Sidekick Creeper Stool if broken, bent, cracked or damaged parts (including labels) are noted. Any Rolling Stool that appears damaged in any way, operates abnormally or is missing parts should be removed from service immediately. If you suspect that the Rolling Stool was subjected to shock load (a load that was dropped suddenly, unexpectedly, etc.), immediately discontinue use until it has been checked by a factory authorized service center.



Thank you very much for choosing an OEMTOOLS® Product!

For future reference, please register your new tool at www.oem-tools.com and complete the owner's record below:

Model: _____ **Purchase Date:** _____

Save the receipt, warranty and these instructions. It is important that you read the entire manual to become familiar with this product before you begin using it. This product is designed for certain applications only. OEMTOOLS® cannot be responsible for issues arising from modification. We strongly recommend that this product is not modified and/or used for any application other than that for which it was designed. If you have any questions relative to a particular application, DO NOT use the product until you have first contacted customer service to determine if it can or should be performed on the product.

⚠️WARNING: This product can expose you to chemicals, including DEHP and lead, which are known to the State of California to cause cancer and birth defects or other reproductive harm. For more information, go to www.P65Warnings.ca.gov.



SIDEKICK CREEPER STOOL

IMPORTANT INSTRUCTIONS AND SAFETY RULES

1. Know your product. Read this manual carefully. Learn the product's applications and limitations, as well as potential hazards specific to it.
2. Keep work area clean and well lit. Cluttered or dark work areas invite accidents.
3. Keep children away. All children should be kept away from the work area. Never let a child handle tools or equipment without strict adult supervision.
4. DO NOT operate this product if under the influence of alcohol or drugs. Read warning labels on prescriptions to determine if your judgment or reflexes are impaired while taking drugs. If there is any doubt, DO NOT attempt to operate.
5. Use safety equipment. Eye protection should be worn at all times when operating this tool. Use ANSI approved safety glasses. Everyday eyeglasses are NOT safety glasses. Dust mask, non-skid safety shoes, hard hat or hearing protection should be used in appropriate conditions.
6. Wear proper apparel. Loose clothing, gloves, neck-ties, rings, bracelets or other jewelry may present a potential hazard when operating this product. Keep all apparel clear of the product.
7. DO NOT overreach. Keep proper footing and balance at all times when operating this product.
8. Check for damage. Check equipment regularly. If part of the product is damaged, it should be carefully inspected to make sure that it can perform its intended function correctly. If in doubt, discontinue use of product.
9. Keep away from flammables. DO NOT attempt to operate this product near flammable materials or combustibles. Failure to comply may cause serious injury or death.
10. Store this product out of the reach of children and untrained persons. This product may be dangerous in the hands of untrained users.
11. Keep this product dry and clean.
12. Use only accessories that are recommended by the manufacturer for your model. Accessories that may be suitable for one product may become hazardous when used on another product.
13. Service must be performed only by qualified repair personnel. Service or maintenance performed by unqualified personnel could result in a risk of injury.
14. When servicing a product, use only identical replacement parts. Use of unauthorized parts or failure to follow maintenance instructions may create a risk of injury.
15. Maintain a safe working environment. Keep the work area well lit. Make sure there is adequate surrounding workspace. Keep the work area free of obstructions, grease, oil, trash, and other debris. DO NOT use this product in a damp or wet location.
16. Maintain labels and nameplates on this product. These carry important information. If unreadable or missing, contact OEMTOOLS® for a replacement.
17. Keep this product dry, clean, and free from brake fluid, oil, and grease.
18. Avoid accidental fire. DO NOT smoke near this product.

19. The warnings, precautions, and instructions discussed in this manual cannot cover all possible conditions and situations that may occur. The operator must understand that common sense and caution are factors which cannot be built into this product, but must be supplied by the operator.
20. We believe the information contained herein to be reliable. However, general technical information is given by us without charge and the user shall employ such information at their own discretion and risk. We assume no responsibility for results or damages incurred from the use of such information in whole or in part.
21. The manufacturer declines any and all responsibility for property damage or injury if said damage is the result of unskillful handling by the operator or of failure to observe the basic safety rules set forth in the instruction manual.
22. The procedures documented in this manual are to serve as guidelines for the use of this equipment.
23. The use of this equipment is simple and straightforward if you follow the instructions. When operating this equipment, use common sense, and only use this equipment for its intended purpose.

PRODUCT DESCRIPTION

The OEMTOOLS® 24987 Sidekick Creeper Stool is designed for easy access to tools and supplies. Large open trays allow user to carry a wide range of items with additional holster caddies on the side for rapid access to the user's items. The slide out under seat drawer can be used to store and organize smaller items.

PRODUCT SPECIFICATIONS

Length	17.72"
Width	14.96"
Height	14.96"
Weight	20.9 Lb.
Weight Capacity	300 Lb.

SPECIFIC SAFETY INSTRUCTIONS AND WARNINGS

1. DO NOT place under automobile tires to move or reposition vehicle.
2. DO NOT use as a toy or skateboard.
3. DO NOT stand on unit or use as a stepping device.
4. DO NOT use if one or more wheels are inoperative. Repair before re-use.
5. DO NOT use if any part of the support structure is broken, split or cracked.
6. When not in use, unit should be stored in a secure place.
7. Always store in an upright position.
8. Keep out of the reach of children.

ASSEMBLY

1. Put the screw (#7) go through the hole of the caster (#5) then go through the hole of plastic body (#1).
2. Put the sleeve (#6) through the screw (#7).
3. Settle the caster with flat washer (#4) and nut M6 (#3).



SIDEKICK CREEPER STOOL

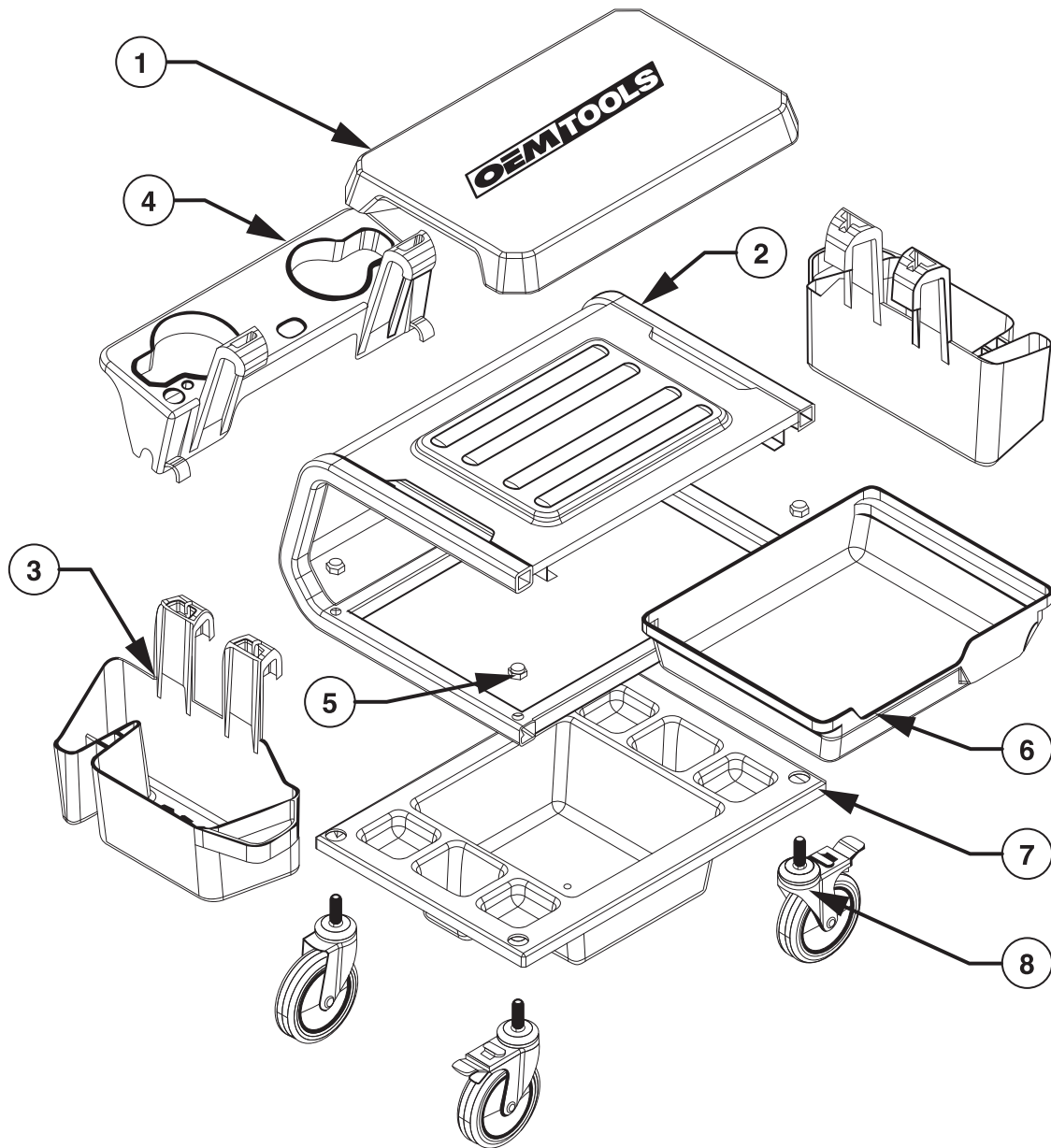

Figure	Description	Qty.
1	Seat Cover	1
2	Seat Creeper Frame	1
3, 4, 6, 7	Removable Trays	5
5	Nuts	4
8	Wheels	4

NOTE: Not all components of the Sidekick Creeper Stool are replacement items, but are illustrated as a convenient reference for location and position in the assembly sequence. The manufacturer and/or distributor have provided the parts list and assembly diagram in this manual as a reference tool only. Neither the manufacturer nor distributor makes any representation or warranty of any kind to the buyer that he or she is qualified to make any repairs to the product, or that he or she is qualified to replace any parts of the product. In fact, the manufacturer and/or distributor expressly states that all repairs and parts replacements should be undertaken by certified and licensed technicians, and not by the buyer. The buyer assumes all risk and liability arising out of his or her repairs to the original product or replacement parts thereto, or arising out of his or her installation of replacement parts thereto.



SIDEKICK CREEPER STOOL

OEMTOOLS® ONE YEAR WARRANTY

For up to one year from the date of purchase of this OEMTOOLS® product, if you find any defect in material or workmanship (through normal usage), return it to the place of purchase or to OEMTOOLS® for repair or replacement at our discretion. In order to obtain this service, send the product and proof of purchase (transportation pre-paid) to:

OEMTOOLS® Q.A. Dept, 3580 E. Raines Road #3, Memphis, TN 38118.

We will not be responsible for lost or damaged goods during transportation; please insure your package. If our inspection verifies the defect, we will either repair or replace the product, or we may elect to refund the purchase price if we cannot readily and quickly provide you with a replacement. We will return repaired products at our expense, but if we determine there is no defect, or that the defect resulted from causes not within the scope of our warranty, then you must bear the cost of returning the product.

OEMTOOLS® does not provide warranty for products labeled other than OEM® or OEMTOOLS®. OEMTOOLS® will not provide any warranty for products subjected to abnormal use. Abnormal use includes (but is not limited to) abuse, accident, alteration, neglect, and unauthorized or unreasonable use or repairs. This warranty does not cover bits, blades, files, batteries, or calibration. We recommend that you maintain your tools and sharpen or replace blades, bits, files, and batteries as necessary. OEMTOOLS® reserves the right to make any changes in construction or design at any time without any obligation in incorporating such changes to tools or equipment previously sold.

OEMTOOLS® makes every effort to ensure that its products meet high quality and durability standards, and warrants to the original purchaser that this product is free from defects in materials and workmanship for the period of one year from the date of purchase. This warranty does not apply to damage due directly or indirectly to misuse, abuse, negligence or accidents, repairs or alterations outside our facilities, criminal activity, improper installation, normal wear and tear, or to lack of maintenance.

We shall in no event be liable for death, injuries to persons or property, or for incidental, contingent, special or consequential damages arising from the use of our product. Some states do not allow the exclusion or limitation of incidental or consequential damages, so the above limitation of exclusion may not apply to you. THIS WARRANTY IS EXPRESSLY IN LIEU OF ALL OTHER WARRANTIES, EXPRESS OR IMPLIED, INCLUDING THE WARRANTIES OF MERCHANTABILITY AND FITNESS. This warranty gives you specific legal rights, and you may also have other rights, which vary from state to state.

Don't forget to register your new OEMTOOLS® product at www.oem-tools.com.

CONTACT US

3580 E. Raines Road, Suite 3, Memphis, TN 38118
Tel: 1-866-458-2472
www.oem-tools.com