

Please read and save these instructions. Read through this owner's manual carefully before using product. Protect yourself and others by observing all safety information, warnings, and cautions. Failure to comply with instructions could result in personal injury and/or damage to product or property. Please retain instructions for future reference.



## WORKSHOP SEAT AND STEP STOOL

### FOR CUSTOMER SERVICE

Technical Question?

**CALL 1-866-458-2472**  
customerservice@oem-tools.com

### UNPACKING

After unpacking the unit, inspect carefully for any damage that may have occurred during transit. Check for loose, missing, or damaged parts. If any damage is observed, a shipping damage claim must be filed with the carrier. DO NOT use the OEMTOOLS® 24904 Workshop Seat and Step Stool if broken, bent, cracked or damaged parts (including labels) are noted. Any Workshop Seat and Step Stool that appears damaged in any way, operates abnormally or is missing parts should be removed from service immediately. If you suspect that the Workshop Seat and Step Stool was subjected to shock load (a load that was dropped suddenly, unexpectedly, etc.), immediately discontinue use until it has been checked by a factory authorized service center.



### **⚠ WARNING**

The following safety information is provided as a guideline to help you operate your Workshop Seat and Step Stool under the safest possible conditions. Any tool or piece of equipment can be potentially dangerous to use when safety or safe handling instructions are not known or not followed. The following safety instructions are to provide the user with the information necessary for safe use and operation. Please read and retain these instructions for the continued safe use of your Workshop Seat and Step Stool. Failure to follow instructions listed below may result in serious injury. In addition, make sure that anyone who uses the equipment understands and follows these safety instructions as well.

### Explanation of Safety Signal Words

**⚠ WARNING:** Indicates a potentially hazardous situation which, if not avoided, could result in death or serious injury.

**⚠ CAUTION:** Indicates a potentially hazardous situation which, if not avoided, may result in minor or moderate injury.

**CAUTION:** Used without the safety alert symbol indicates a potentially hazardous situation which, if not avoided, may result in property damage.

**NOTES:** Provide clarity and helpful information.

Thank you very much for choosing an OEMTOOLS® Product!

For future reference, please register your new tool at [www.oem-tools.com](http://www.oem-tools.com) and complete the owner's record below:

**Model:** \_\_\_\_\_ **Purchase Date:** \_\_\_\_\_

Save the receipt, warranty and these instructions. It is important that you read the entire manual to become familiar with this product before you begin using it. This product is designed for certain applications only. OEMTOOLS® cannot be responsible for issues arising from modification. We strongly recommend that this product is not modified and/or used for any application other than that for which it was designed. If you have any questions relative to a particular application, DO NOT use the product until you have first contacted customer service to determine if it can or should be performed on the product.

**⚠ WARNING:** Pursuant to California Proposition 65, this product contains chemicals known to the state of California to cause cancer and birth defects or other reproductive harm. Wash hands after handling.



## WORKSHOP SEAT AND STEP STOOL

### **! IMPORTANT INSTRUCTIONS AND SAFETY RULES**

1. Know your product. Read this manual carefully. Learn the product's applications and limitations, as well as potential hazards specific to it.
2. Keep work area clean and well lit. Cluttered or dark work areas invite accidents.
3. Keep children away. All children should be kept away from the work area. Never let a child handle tools or equipment without strict adult supervision.
4. DO NOT operate this product if under the influence of alcohol or drugs. Read warning labels on prescriptions to determine if your judgment or reflexes are impaired while taking drugs. If there is any doubt, DO NOT attempt to operate.
5. Use safety equipment. Eye protection should be worn at all times when operating this tool. Use ANSI approved safety glasses. Everyday eyeglasses are NOT safety glasses. Dust mask, non-skid safety shoes, hard hat or hearing protection should be used in appropriate conditions.
6. Wear proper apparel. Loose clothing, gloves, neck-ties, rings, bracelets or other jewelry may present a potential hazard when operating this product. Keep all apparel clear of the product.
7. DO NOT overreach. Keep proper footing and balance at all times when operating this product.
8. Check for damage. Check equipment regularly. If part of the product is damaged, it should be carefully inspected to make sure that it can perform its intended function correctly. If in doubt, discontinue use of product.
9. Keep away from flammables. DO NOT attempt to operate this product near flammable materials or combustibles. Failure to comply may cause serious injury or death.
10. Store this product out of the reach of children and untrained persons. This product may be dangerous in the hands of untrained users.
11. Keep this product dry and clean.
12. Use only accessories that are recommended by the manufacturer for your model. Accessories that may be suitable for one product may become hazardous when used on another product.
13. Service must be performed only by qualified repair personnel. Service or maintenance performed by unqualified personnel could result in a risk of injury.
14. When servicing a product, use only identical replacement parts. Use of unauthorized parts or failure to follow maintenance instructions may create a risk of injury.
15. Maintain a safe working environment. Keep the work area well lit. Make sure there is adequate surrounding workspace. Keep the work area free of obstructions, grease, oil, trash, and other debris. DO NOT use this product in a damp or wet location.
16. Maintain labels and nameplates on this product. These carry important information. If unreadable or missing, contact OEMTOOLS® for a replacement.
17. Keep this product dry, clean, and free from brake fluid, oil, and grease.
18. Avoid accidental fire. DO NOT smoke near this product.
19. The warnings, precautions, and instructions discussed in this manual cannot cover all possible conditions and situations that may occur. The operator must understand that common sense and caution are factors which cannot be built into this product, but must be supplied by the operator.
20. We believe the information contained herein to be reliable. However, general technical information is given by us without charge and the user shall employ such information at their own discretion and risk.

We assume no responsibility for results or damages incurred from the use of such information in whole or in part.

21. The manufacturer declines any and all responsibility for property damage or injury if said damage is the result of unskillful handling by the operator or of failure to observe the basic safety rules set forth in the instruction manual.
22. The procedures documented in this manual are to serve as guidelines for the use of this equipment.
23. The use of this equipment is simple and straightforward if you follow the instructions. When operating this equipment, use common sense, and only use this equipment for its intended purpose.

### PRODUCT DESCRIPTION

The OEMTOOLS® 24904 Workshop Seat and Step Stool is a 2-in-1 creeper seat and step stool. When used as a creeper seat or step stool, it will support and move rated capacity loads consisting of a single person weighing no more than 352 Lb. This device is not intended, designed or engineered to be used for any other purpose.

### PRODUCT SPECIFICATIONS

Rated Capacity	352 Lb.
Seat Size	14" x 7-7/8"
Step Size	14" x 9"

### CONTENTS

- (1) Seat Pad Section, (1) Caster Frame Section, (1) Tool Tray,  
(2) Side Frame Sections, (2) Seat Support Brackets and U-brackets,  
(5) Casters, assorted hardware.

### SPECIFIC SAFETY INSTRUCTIONS AND WARNINGS

Save these instructions. For your safety, read, understand, and follow the information provided with and on this device before using. The owner and/or operator shall have an understanding of the device, its operating characteristics and safety operating instructions before operating the equipment. The owner and/or operator shall be aware that use and repair of this product may require special skills and knowledge. Instructions and safety information shall be read to and discussed with the operator in the operator's native language, making sure that the operator comprehends their contents, before use of this equipment is authorized. If any doubt exists as to the safe and proper use of this device, remove from service immediately.

**!WARNING:** Inspect before each use. Do not use if abnormal conditions such as cracked welds, damaged, loose or missing parts are noted. Any equipment that appears damaged in any way, is found to be worn, or operates abnormally shall be removed from service until repaired. If the equipment has been or is suspected to have been subjected to an abnormal load or shock, immediately discontinue use until inspected by a factory authorized repair facility (contact distributor or manufacturer for list of authorized repair facilities). It is recommended that an annual inspection be made by an authorized repair facility. Labels and Operator's Manuals are available from the manufacturer.

**!WARNING:** DO NOT use this device for any purpose other than that for which it is expressly intended.

1. Clean any mud, grease, oil or slippery liquids before using creeper step stool.
2. DO NOT exceed rated capacity. Rated capacity is 352 Lb. (includes user, tools, and equipment).
3. Sit down gently. Avoid shock loads caused by jumping or falling on seat.
4. DO NOT stand on seat.



# WORKSHOP SEAT AND STEP STOOL

5. When used as a step stool, device must be on firm, level surface with all four legs contacting ground.
6. Make sure step stool is appropriate height for intended purpose. DO NOT overreach.
7. Only one person shall use step stool at a time.
8. Keep out of the reach of children. This device is not appropriate for children's use.
9. Use on smooth, level surfaces only.

## PREPARATION/ASSEMBLY

Before assembling your Creeper, make sure all parts are present. If any part is missing or damaged, do not attempt to assemble or use the product. Contact OEMTOOLS® customer service for replacement parts, 1-866-458-2472.

1. With the Seat Cushion facing down, align the holes of the Crossbars with the seat. Then align the holes of the Seat bracket and U-braket and attach with four M6 x 16 Phillips Head Screws as shown in Figure 1.

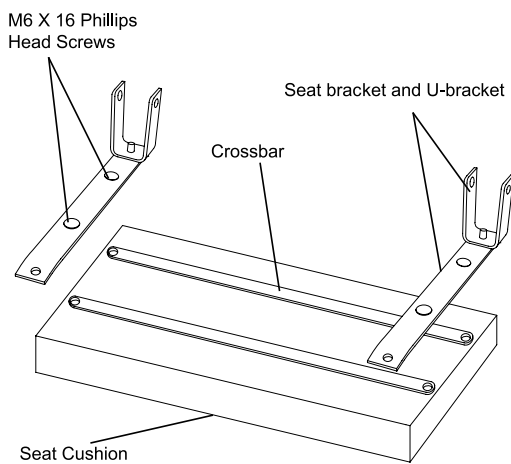

Figure 1 - Attaching U-brackets

2. Assemble Tool Tray and five Casters to Caster Frame using Allen Head binding barrels. Then attach two Creeper Side Frames to Caster Frame with two M8 x 60 Hex Head Bolts, two Washers and two Acorn Nuts each as shown in Figure 2.

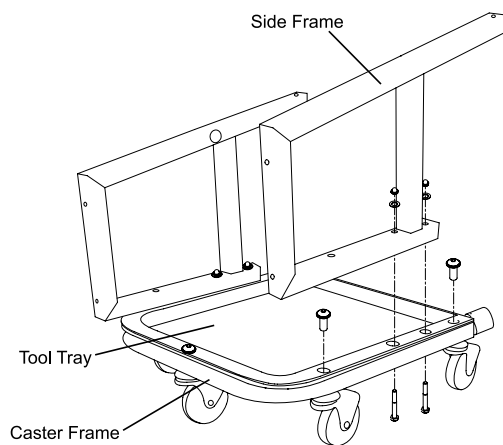

Figure 2 - Assembling tool tray and casters

3. Attach Creeper Seat to Creeper Side Frames using two M6 x 40 Phillips Head Screws, with Washers, and Nuts, and two M6 x 14 Phillips Head Screws as in Figure 3.

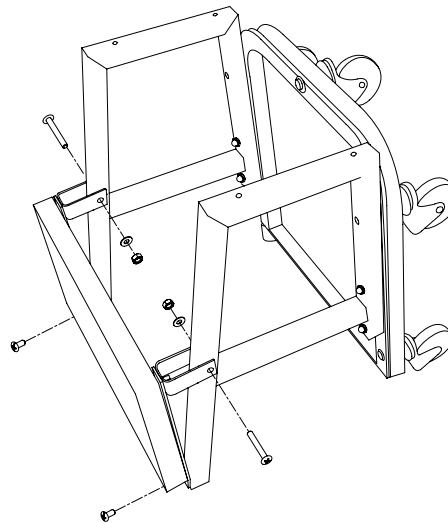

Figure 3 - Attaching Creeper Seat

4. Fasten Creeper Step to Side Frames using four M6 x 16 Phillips Head Screws (Fig. 4).

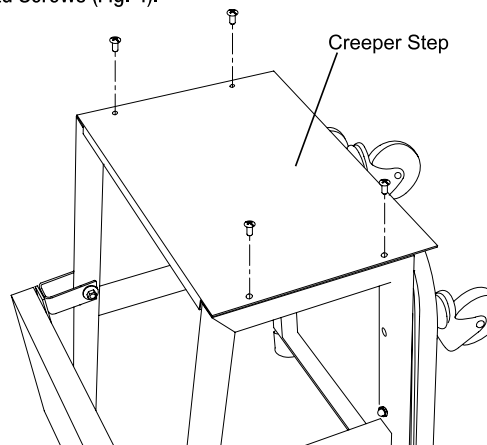

Figure 4 - Attaching Step to Side Frames

## MAINTENANCE

Wipe clean as needed. Use mild upholstery cleaner (not caustic) to clean seat as needed.

**CAUTION:** DO NOT lubricate casters



# WORKSHOP SEAT AND STEP STOOL

## PRODUCT LAYOUT

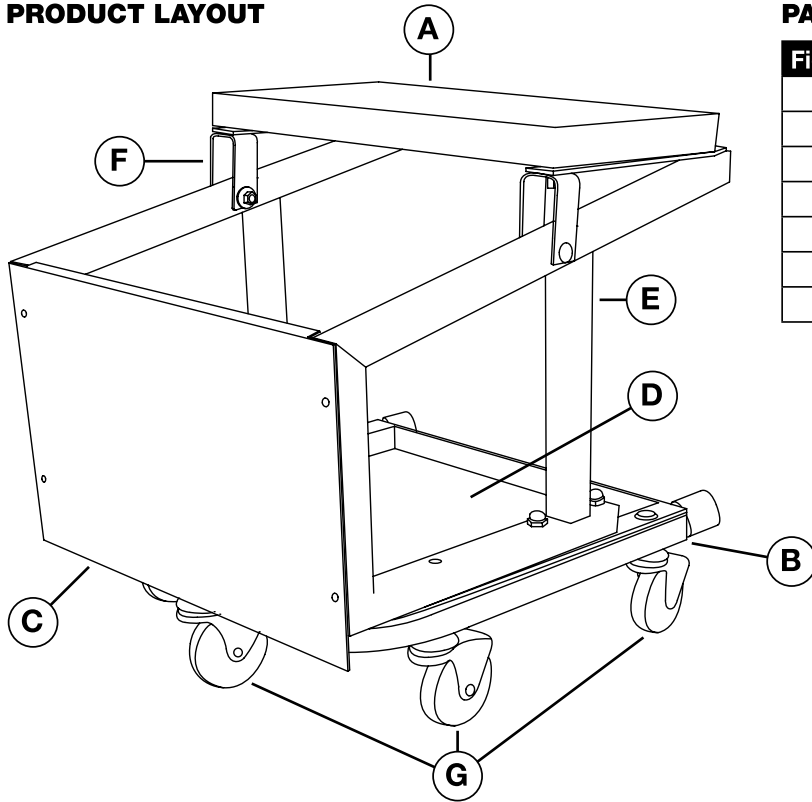

## PARTS LIST

Figure	Description	Qty.
A	Seat Pad Section	1
B	Caster Frame Section	1
C	Creeper Seat	1
D	Tool Tray	1
E	Side Frame Sections	2
F	Seat Support Brackets & U-brackets	2
G	Casters	5

## OEMTOOLS® 1 YEAR WARRANTY

For up to one year from the date of purchase of this OEMTOOLS® product, if you find any defect in material or workmanship (through normal usage), return it to the place of purchase or to OEMTOOLS® for repair or replacement at our discretion. In order to obtain this service, send the product and proof of purchase (transportation pre-paid) to:

OEMTOOLS® Q.A. Dept, 3580 E. Raines Road #3, Memphis, TN 38118.

We will not be responsible for lost or damaged goods during transportation; please insure your package. If our inspection verifies the defect, we will either repair or replace the product, or we may elect to refund the purchase price if we cannot readily and quickly provide you with a replacement. We will return repaired products at our expense, but if we determine there is no defect, or that the defect resulted from causes not within the scope of our warranty, then you must bear the cost of returning the product.

OEMTOOLS® does not provide warranty for products labeled other than OEM® or OEMTOOLS®. OEMTOOLS® will not provide any warranty for products subjected to abnormal use. Abnormal use includes (but is not limited to) abuse, accident, alteration, neglect, and unauthorized or unreasonable use or repairs. This warranty does not cover bits, blades, files, batteries, or calibration. We recommend that you maintain your tools and sharpen or replace blades, bits, files, and batteries as necessary. OEMTOOLS® reserves the right to make any changes in construction or design at any time without any obligation in incorporating such changes to tools or equipment previously sold.

OEMTOOLS® makes every effort to ensure that its products meet high quality and durability standards, and warrants to the original purchaser that this product is free from defects in materials and workmanship for the period of one year from the date of purchase. This warranty does not apply to damage due directly or indirectly to misuse, abuse, negligence or accidents, repairs or alterations outside our facilities, criminal activity, improper installation, normal wear and tear, or to lack of maintenance.

We shall in no event be liable for death, injuries to persons or property, or for incidental, contingent, special or consequential damages arising from the use of our product. Some states do not allow the exclusion or limitation of incidental or consequential damages, so the above limitation of exclusion may not apply to you. THIS WARRANTY IS EXPRESSLY IN LIEU OF ALL OTHER WARRANTIES, EXPRESS OR IMPLIED, INCLUDING THE WARRANTIES OF MERCHANTABILITY AND FITNESS. This warranty gives you specific legal rights, and you may also have other rights, which vary from state to state.

Don't forget to register your new OEMTOOLS® product at [www.oem-tools.com](http://www.oem-tools.com).

## CONTACT US

3580 E. Raines Road, Suite 3, Memphis, TN 38118  
 Tel: 1-866-458-2472  
[www.oem-tools.com](http://www.oem-tools.com)

