

Please read and save these instructions. Read through this owner's manual carefully before using product. Protect yourself and others by observing all safety information, warnings, and cautions. Failure to comply with instructions could result in personal injury and/or damage to product or property. Please retain instructions for future reference.



22 TON AIR/HYDRAULIC JACK

FOR CUSTOMER SERVICE

Technical Question?

CALL 1-866-458-2472

customerservice@oem-tools.com

UNPACKING

After unpacking unit, inspect carefully for any damage that may have occurred during transit. Check for loose, missing, or damaged parts. If any damage is observed, a shipping damage claim must be filed with carrier. Do not use the Hydraulic Truck Jack if broken, bent, cracked or damaged parts (including labels) are noted. Any Hydraulic Truck Jack that appears damaged in any way, operates abnormally or is missing parts should be removed from service immediately. If you suspect that the Hydraulic Truck Jack was subjected to a shock load (a load that was dropped suddenly, unexpectedly, etc.) immediately discontinue use until it has been checked by a factory authorized service center.



⚠ WARNING

The following safety information is provided as guidelines to help you operate your 22 Ton Air/Hydraulic Jack under the safest possible conditions. Any tool or piece of equipment can be potentially dangerous to use when safety or safe handling instructions are not known or not followed. The following safety instructions are to provide the user with the information necessary for safe use and operation. Please read and retain these instructions for the continued safe use of your service system. Failure to follow instructions listed below may result in serious injury. In addition, make certain that anyone that uses the equipment understands and follows these safety instructions as well.

WARNING: This product contains chemicals known to the State of California to cause cancer and birth defects or other reproductive harm.

Explanation of Safety Signal Words

⚠ WARNING : Indicates a potentially hazardous situation which, if not avoided, could result in death or serious injury.

⚠ CAUTION : Indicates a potentially hazardous situation which, if not avoided, may result in minor or moderate injury.

CAUTION : Used without the safety alert symbol indicates a potentially hazardous situation which, if not avoided, may result in property damage.

Notes : Provide clarity and helpful information.



22 TON AIR/HYDRAULIC JACK

Thank you very much for choosing an OEMTOOLS Product!

For future reference, please complete the owner's record below:

Model: _____ **Purchase Date:** _____

Save the receipt, warranty and these instructions. It is important that you read the entire manual to become familiar with this product before you begin using it. This machine is designed for certain applications only. OEMTOOLS cannot be responsible for issues arising from modification. We strongly recommend this machine is not modified and/or used for any application other than that for which it was designed. If you have any questions relative to a particular application, DO NOT use the machine until you have first contacted OEMTOOLS to determine if it can or should be performed on the product.

For technical questions please call 1-866-458-2472.



IMPORTANT INSTRUCTIONS AND SAFETY RULES

1. Know your tool. Read this manual carefully. Learn the tool's applications and limitations, as well as, potential hazards specific to it.
2. Keep work area clean and well lit. Cluttered or dark work areas invite accidents.
3. Keep children away. All children should be kept away from the work area. Never let a child handle a tool without strict adult supervision.
4. Do not operate this tool if under the influence of alcohol or drugs. Read warning labels on prescriptions to determine if your judgment or reflexes are impaired while taking drugs. If there is any doubt, do not attempt to operate.
5. Use safety equipment. Eye protection should be worn at all times when operating this tool. Use ANSI approved safety glasses. Everyday eyeglasses are NOT safety glasses. Dust mask, non-skid safety shoes, hard hat or hearing protection should be used in appropriate conditions.
6. Wear proper apparel. Loose clothing, gloves, neck-ties, rings, bracelets or other jewelry may present a potential hazard when operating this tool. Keep all apparel clear of the tool.
7. Don't overreach. Keep proper footing and balance at all times when operating this tool.
8. Check for damage. Check your tool regularly. If part of the tool is damaged it should be carefully inspected to make sure that it can perform its intended function correctly. If in doubt, the part should be repaired. Refer all servicing to a qualified technician. Consult your dealer for advice.
9. Keep away from flammables. Do not attempt to operate this tool near flammable materials or combustibles. Failure to comply may cause serious injury or death.
10. Store idle tools out of the reach of children and untrained persons. Tools may be dangerous in the hands of untrained users.
 - Maintain tools with care.
 - Keep tools dry and clean.
 - Properly maintained tools are less likely to bind and are easier to control. Do not use a damaged tool. Tag damaged tools "Do not use" until repaired.
 - Check for misalignment or binding of moving parts, breakage of parts, and any other condition that may affect the tool's operation.
 - If damaged, have the tool serviced before using. Many accidents are caused by poorly maintained tools.
 - Use only accessories that are recommended by the manufacturer for your model. Accessories that may be suitable for one tool may become hazardous when used on another tool.
 - Tool service must be performed only by qualified repair personnel. Service or maintenance performed by unqualified personnel could result in a risk of injury.
 - When servicing a tool, use only identical replacement parts. Use of unauthorized parts or failure to follow maintenance instructions may create a risk of injury.
 - Maintain a safe working environment. Keep the work area well lit. Make sure there is adequate surrounding workspace. Keep the work area free of obstructions, grease, oil, trash, and other debris. Do not use this product in a damp or wet location.
 - Maintain labels and nameplates on this product. These carry important information. If unreadable or missing, contact OEM for a replacement.



22 TON AIR/HYDRAULIC JACK

- Keep the handle dry, clean, and free from brake fluid, oil, and grease.
- Before use, read and understand all warnings, safety precautions, and instructions as outlined in the vehicle manufacturer's service manual. It is beyond the scope of this manual to properly describe the correct procedure and test data for each vehicle.
- Always perform vehicle service in a properly ventilated area. Never run an engine without proper ventilation for its exhaust. Stop work and take necessary steps to improve ventilation in the work area if you develop momentary eye, nose, or throat irritation as this indicates inadequate ventilation.
- Engine parts that are in motion and unexpected movement of a vehicle can injure or kill. When working near moving engine parts, wear snug fit clothing and keep hands and fingers away from moving parts. Keep hoses and tools clear of moving parts. Always stay clear of moving engine parts. Hoses and tools can be thrown through the air if not kept clear of moving engine parts.
- The unexpected movement of a vehicle can injure or kill. When working on vehicles always set the parking brake or block the wheels.
- Avoid accidental fire and/or explosion. Do not smoke near engine fuel and battery components.
- The warnings, precautions, and instructions discussed in this manual cannot cover all possible conditions and situations that may occur. The operator must understand that common sense and caution are factors which cannot be built into this product, but must be supplied by the operator.
- For safety purposes and the prevention of damage to expensive components it is advised that the user have an understanding of basic automotive repair and a working knowledge of automotive systems.
- We believe the information contained herein to be reliable. However, general technical information is given by us without charge and the user shall employ such information at their own discretion and risk. We assume no responsibility for results or damages incurred from the use of such information in whole or in part. Always refer to specific instructions and technical information supplied by vehicle manufacturer.
- The manufacturer declines any and all responsibility for damage to vehicles or components if said damage is the result of unskillful handling by the operator or of failure to observe the basic safety rules set forth in the instruction manual.
- This equipment is intended only for professional use by personnel trained in performing the service functions for which it has been designed.
- This equipment is designed for servicing a variety of vehicles in a safe, convenient manner. However, differences in vehicle makes and models may make it impossible to use this equipment as it is intended. Do not attempt to force the use of this equipment on an application for which it is not designed to perform.
- The procedures documented in this manual are to serve as guidelines for the use of this equipment.
- In addition to these guidelines, always follow the manufacturer's recommended procedures when servicing each unique vehicle.
- The use of this equipment is simple and straightforward if you follow the instructions. When operating this equipment, use common sense, and always stop to think before using a Hydraulic Truck Jack or lifting a vehicle.

PRODUCT SPECIFICATIONS

Capacity	22 Ton
Minimum Height	8-7/8"
Ram Travel	4-3/4"
Screw Adjustment	4-1/8"
Wheel Diameter	8"
Air Pressure	110-125 Psi
Air Hose	3/8" x 48"
Air Inlet Fitting	1/4" NPT



22 TON AIR/HYDRAULIC JACK

PRODUCT DESCRIPTION

The heavy-duty OEMTOOLS 22-Ton Air/Hydraulic Truck Service Axle Jack has a powerful air motor to lift heavy loads with ease. The compact design easily fits between dual tandem axles. Large rear wheels make it easy to maneuver for quick positioning. This jack is great for lifting axles, farm vehicles, heavy-duty machinery and industrial construction equipment.

NEVER use for any purpose other than those uses outlined above!

1. Verify that the product and application are compatible, if in doubt call OEMTOOLS at 1-866-458-2472.
2. Before using this product, read the operator's manual completely and familiarize yourself thoroughly with the product, its components and recognize the hazards associated with its use.
3. Wear appropriate safety gear, including heavy-duty work gloves and ANSI-approved safety goggles during use.
4. Ensure that jack rolls freely. Raise and lower the unloaded jack throughout the lifting range before putting into service to ensure the pump operates smoothly. Replace worn or damaged parts.
5. Do not exceed the weight capacity of the jack. Make sure weight is evenly distributed. Be aware of dynamic loading! Sudden load movement may briefly create excess load causing product failure. Exceeding the maximum capacity for this product is dangerous and can lead to serious injury or property damage.
6. Always evaluate your task before using this jack. Hydraulic Truck Jacks are designed to lift, but not support, rated capacity partial vehicle loads consisting of one end of a vehicle. Immediately after lifting, support loads with a pair of appropriately rated jack stands. Use as intended only.
7. Use only on a hard, level and flat surface capable of bearing the combined weight of the Hydraulic Truck Jack, the load being lifted, the operator and any tools being used.
8. If you are working and the load becomes off-balance and/or the jack begins to tip over, **DO NOT ATTEMPT TO CATCH OR LIFT THE LOAD WHEN FALLING. SERIOUS PERSONAL INJURY CAN RESULT!** In this event, clear the area as quickly and safely as possible in order to avoid injury from the falling load, including getting hit with flying fragments.

9. Before each use, inspect the general condition of the Hydraulic Truck Jack. Check for oil leaks, jack operation, loose components, free rotation and pivoting of saddle adjustment components. If a problem occurs, have the problem corrected before further use.

TO PREVENT SERIOUS INJURY: DO NOT USE A DAMAGED OR MALFUNCTIONING JACK

10. If in doubt about the safety of your project, we advise you to have the work done by a professional familiar with applicable safety practices.

ASSEMBLY

Install the Handle Assembly according to the assembly drawing.

OPERATION

Lifting Vehicle

Always transfer the load to appropriately rated jack stands.

Do not work under a load which is supported only by a jack.

Never tie, clamp or disable the lift control valve. Only attachments and/or adapters supplied by the manufacturer shall be used.

1. Connect an adequate air source to the air supply inlet.
2. Before first use of this product, pour a teaspoon of good quality air tool lubricant into the hose quick coupler plug, then connect it to air source and turn on the air valve and operate for 3 seconds to evenly distribute lubricant.

Follow the vehicle manufacturer's recommended guidelines for lifting and the location of recommended lift points.

3. Engage the emergency brake and chock each unlifted wheel in both directions to prevent inadvertent vehicle movement.
4. Close the release valve by turning the handle wheel (31) clockwise until it is firmly closed.
5. Apply the emergency brake and use wheel chocks to block all wheels to prevent any movement of the vehicle being lifted.
6. Adjust the handle angle to place the jack into position and adjust the extension screw as needed.



22 TON AIR/HYDRAULIC JACK

7. Connect the quick coupler-male into the shop air supply hose quick coupler-female, and then turn on the air valve.
8. Raise the load to desired height, turn off the air valve and immediately USE JACK STANDS with adequate capacity to support the load.

Lowering Vehicle

Be sure all tools and personnel are clear before lowering load.

9. When work is done, disconnect the quick coupler-male from the air source and carefully remove the jack stands.
10. SLOWLY and CAREFULLY lower the load by turning the hand wheel counterclockwise in extremely small increments, then lower the extension screw by turning it clockwise as needed and remove the jack.

WARNING

Dangerous dynamic shock loads are created by quick opening and closing the release valve when the load is being lowered. The resulting overload may cause hydraulic system failure which could cause severe personal injury and/or property damage.

The manufacturer and/or distributor have provided the parts list and assembly diagram in this manual as a reference tool only. Neither the manufacturer nor distributor makes any representation or warranty of any kind to the buyer that he or she is qualified to make any repairs to the product, or that he or she is qualified to replace any parts of the product. In fact, the manufacturer and/or distributor expressly states that all repairs and parts replacements should be undertaken by certified and licensed technicians, and not by the buyer. The buyer assumes all risk and liability arising out of his or her repairs to the original product or replacement parts thereto, or arising out of his or her installation of replacement parts thereto.

Note: Not all components of the Hydraulic Truck Jack are replacement items, but are illustrated as a convenient reference for location and position in the assembly sequence.

Use caution when troubleshooting a malfunctioning jack. Stay well clear of the supported load. Completely resolve all problems before use. If the jack is malfunctioning, have a qualified technician inspect and repair the jack before use. After the jack is repaired: Test it carefully without a load by raising it and lowering it fully, checking for proper operation.

MAINTENANCE

Important: Use only good grade hydraulic jack oil. Avoid mixing different types of fluid and NEVER use brake fluid, turbine oil, transmission fluid, motor oil or glycerin. Improper fluid can cause premature failure of the jack and the potential for sudden and immediate loss of load.

1. Clean the outside of the jack with dry, clean and soft cloth and periodically lubricate the joints, extension screw and all moving parts with light oil as needed.
2. When not in use, store the jack in a dry location with ram and extension screw fully lowered.
3. Purge the hydraulic system to eliminate any air in the system if jack efficiency drops: turn the hand wheel 1-1/2 turns counterclockwise and remove the oil filler plug by gently pulling, connect the air inlet fitting to air source, turn on the air valve and work for a while, close the hand wheel clockwise firmly and check the hydraulic oil level, if not adequate, top off jack reservoir with high quality hydraulic jack oil as described above, then replace the filler plug.
4. Check the hydraulic oil: place the jack in an upright position, completely lower the ram and remove the filler plug, if it is not adequate, fill with high quality hydraulic jack oil to the lower rim of the fill hole, purge away air from the hydraulic system as described above, top off with more hydraulic oil, then replace the filler plug.
5. For best performance and longest life, replace the complete jack oil at least once per year: With the ram fully lowered, remove the oil filler plug, lay the jack on its side and drain the oil into a suitable container, then fill with high quality hydraulic jack oil as described above, reinstall the filler plug.

NOTE: Dispose of hydraulic oil in accordance with local regulations.



22 TON AIR/HYDRAULIC JACK

Figure	Description	Quantity
24851-1	Screw	8
24851-2	Bolt	2
24851-3	Right Side Plate	1
24851-4	Circlip	2
24851-5	Wheel	2
24851-6	Bolt	5
24851-7	Adjustable Frame	1
24851-8	Base Plate	1
24851-9	Left Side Plate	1
24851-10	Handle Socket	1
24851-11	Washer	1
24851-12	Screw	1
24851-13	Nut	1
24851-14	Connector	1
24851-15	Tie Rod-1	1
24851-16	Tie Rod-2	1
24851-17	Screw	1
24851-18	Handle-1	1
24851-19	Screw	2
24851-20	Handle Connector	1
24851-21	Slotted Pin	1
24851-22	Pin	1
24851-23	Nut	5
24851-24	Spring	1
24851-25	Tie Rod-3 (not shown)	1
24851-26	Screw	1
24851-27	Pin	1
24851-28	Pulling Handle	1
24851-29	Handle Sleeve	2
24851-30	Screw	1
24851-31	Handle Wheel	1
24851-32	Handle-2	1
24851-33	Pump Assembly	1
24851-34	Washer	2
24851-35	Bush	1
24851-36	Set Screw	2
24851-37	Air Hose	1

Figure	Description	Quantity
24851-38	Valve Body	1
24851-39	Quick Coupler-Male	1
24851-40	Screw	4
24851-41	Plate	1
24851-42	U-Bolt	2
24851-43	Saddle Parts	1
24851-44	Pin I	1
24851-45	Pin II	1
24851-46	Pin III	1
24851-47	R Pin	3



22 TON AIR/HYDRAULIC JACK

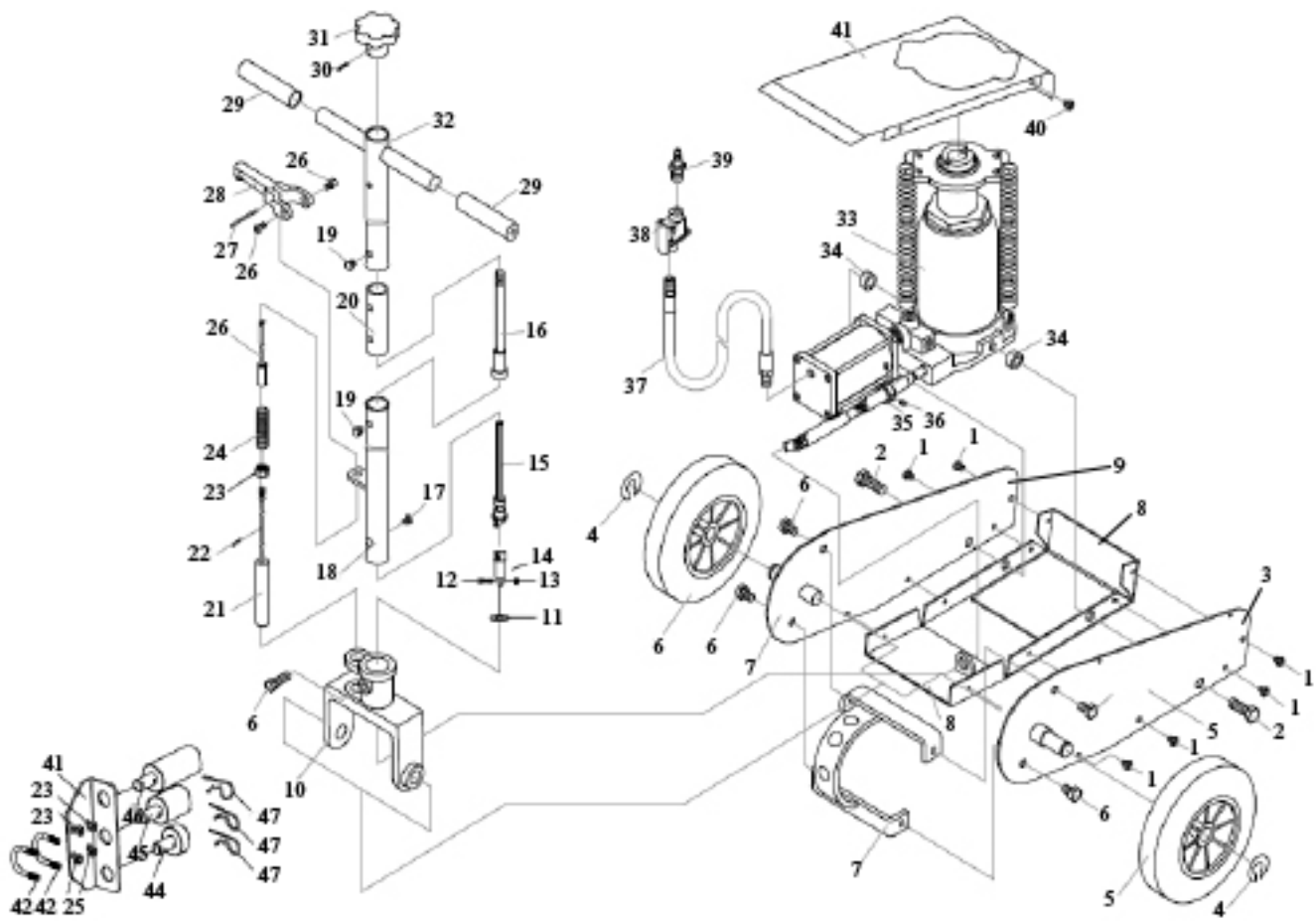



22 TON AIR/HYDRAULIC JACK

RAM Drawing

Figure	Description	Quantity
24851-P01	Air Pump	1
24851-P02	Washer	1
24851-P03	Base Plate	1
24851-P04	Ball	1
24851-P05	Ball Cup	1
24851-P06	Spring	1
24851-P07	Screw	1
24851-P08	O-Ring	1
24851-P09	Screw	1
24851-P10	Plastic Cap	1
24851-P11	Release Valve	1
24851-P12	O-Ring	1
24851-P13	Ball	3
24851-P14	Spring	1
24851-P15	Screw	2
24851-P16	Bolt	4
24851-P17	Ball Cup	1
24851-P18	Oil Filler	1
24851-P19	Ball	1
24851-P20	Packing	1
24851-P21	Reservoir	1
24851-P22	Filler Plug	1
24851-P23	Nylon Ring	1
24851-P24	Cylinder	1
24851-P25	O-Ring	1
24851-P26	Cup Seal	1
24851-P27	Ram	1
24851-P28	Nylon Ring	1
24851-P29	Top Nut	1
24851-P30	O-Ring	1
24851-P31	Spring	4
24851-P32	Spring Plate	1

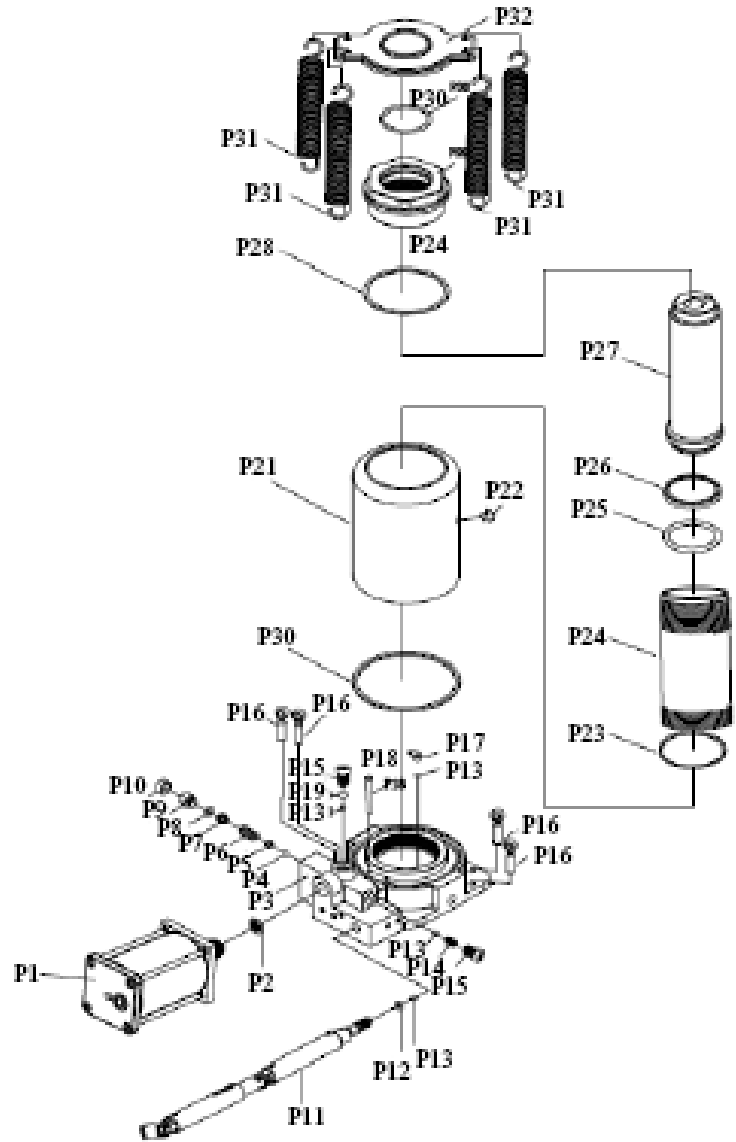



22 TON AIR/HYDRAULIC JACK

OEMTOOLS™ LIMITED 90 DAY WARRANTY

Please read the following carefully

From 90 days from the original purchase of this product, OEMTOOLS will warranty this item. If you find any defect in material or workmanship, through normal usage, return it to the place of purchase or to OEMTOOLS for repair or replacement at our discretion. In order to obtain this service send your tool and proof of purchase, transportation pre-paid, to OEMTOOLS Q.A. Dept., 3580 E. Raines Road #3, Memphis, TN 38118. We will not be responsible for lost or damaged goods during transportation, please insure your package. If our inspection verifies the defect, we will either repair or replace the product at our election, or we may elect to refund the purchase price if we cannot readily and quickly provide you with a replacement. We will return repaired products at our expense, but if we determine there is no defect, or that the defect resulted from causes not within the scope of our warranty, then you must bear the cost of returning the product.

OEMTOOLS does not provide warranty for products labeled other than OEM or OEMTOOLS. OEMTOOLS will not provide any warranty for products subjected to abnormal use. Abnormal use includes, but is not limited to, abuse, accident, alteration, neglect, and unauthorized or unreasonable use or repairs. This warranty does not cover bits, blades, files, batteries, or calibration. We recommend that you maintain your tools and sharpen or replace blades, bits, files, and batteries as necessary. OEMTOOLS reserves the right to make any changes in construction or design at any time without any obligation in incorporating such changes to tools or equipment previously sold.

OEMTOOLS makes every effort to assure that its products meet high quality and durability standards, and warrants to the original purchaser that this product is free from defects in materials and workmanship for the period of 90 days from the date of purchase. This warranty does not apply to damage due directly or indirectly to misuse, abuse, negligence or accidents, repairs or alterations outside our facilities, criminal activity, improper installation, normal wear and tear or to lack of maintenance.

We shall in no event be liable for death, injuries to persons or property, or for incidental, contingent, special or consequential damages arising from the use of our product. Some states do not allow the exclusion or limitation of incidental or consequential damages, so the above limitation of exclusion may not apply to you. THIS WARRANTY IS EXPRESSLY IN LIEU OF ALL OTHER WARRANTIES, EXPRESS OR IMPLIED, INCLUDING THE WARRANTIES OF MERCHANTABILITY AND FITNESS. This warranty gives you specific legal rights, and you may also have other rights, which vary from state to state.

CONTACT US



3580 E. Raines Road, Suite 3, Memphis, TN 38118

Tel: 1-866-458-2472

www.oem-tools.com