

Please read and save these instructions. Read through this owner's manual carefully before using product. Protect yourself and others by observing all safety information, warnings, and cautions. Failure to comply with instructions could result in personal injury and/or damage to product or property. Please retain instructions for future reference.

OEMTOOLS™ 20V MAX* LITHIUM-ION 3/8" DRIVE CORDLESS IMPACT WRENCH

FOR CUSTOMER SERVICE

Technical Question?

CALL 1-866-458-2472
customerservice@oem-tools.com

UNPACKING

After unpacking unit, inspect carefully for any damage that may have occurred during transit. Check for loose, missing, or damaged parts. If any damage is observed, a shipping damage claim must be filed with carrier. DO NOT use the OEMTOOLS™ Impact Wrench if broken, bent, cracked or damaged parts (including labels) are noted. Any Impact Wrench that appears damaged in any way, operates abnormally or is missing parts should be removed from service immediately. If you suspect that the Impact Wrench was subjected to shock load (a load that was dropped suddenly, unexpectedly, etc.), immediately discontinue use until it has been checked by a factory authorized service center.

*Voltage is measured without workload. Maximum initial battery voltage after charging. Nominal voltage is 18 Volts.



⚠ WARNING

The following safety information is provided as a guideline to help you operate your Impact Wrench under the safest possible conditions. Any tool or piece of equipment can be potentially dangerous to use when safety or safe handling instructions are not known or not followed. The following safety instructions are to provide the user with the information necessary for safe use and operation. Please read and retain these instructions for the continued safe use of your service system. Failure to follow instructions listed below may result in serious injury. In addition, make certain that anyone who uses the equipment understands and follows these safety instructions as well.

Explanation of Safety Signal Words

⚠ WARNING: Indicates a potentially hazardous situation which, if not avoided, could result in death or serious injury.

⚠ CAUTION: Indicates a potentially hazardous situation which, if not avoided, may result in minor or moderate injury.

CAUTION: Used without the safety alert symbol indicates a potentially hazardous situation which, if not avoided, may result in property damage.

NOTES: Provide clarity and helpful information.

Thank you very much for choosing an OEMTOOLS™ Product!

For future reference, please register your new tool at www.oem-tools.com and complete the owner's record below:

Model: _____ **Purchase Date:** _____

Save the receipt, warranty and these instructions. It is important that you read the entire manual to become familiar with this product before you begin using it. This product is designed for certain applications only. OEMTOOLS™ cannot be responsible for issues arising from modification. We strongly recommend this product is not modified and/or used for any application other than that for which it was designed. If you have any questions relative to a particular application, DO NOT use the product until you have first contacted customer service to determine if it can or should be performed on the product.

⚠ WARNING: This product can expose you to chemicals, including lead, which are known to the State of California to cause cancer and birth defects or other reproductive harm. For more information, go to www.P65Warnings.ca.gov.

OEMTOOLS™ 20V MAX* LITHIUM-ION 3/8" DRIVE CORDLESS IMPACT WRENCH

POWER TOOL SAFETY

⚠WARNING: Read all safety warnings and instructions. Failure to follow the warnings and instructions may result in electric shock, fire, and/or serious injury. Save all warnings and instructions for future reference.

WORK AREA SAFETY

1. Keep work area clean and well lit. Cluttered or dark areas invite accidents.
2. DO NOT operate power tools in explosive atmospheres, such as in the presence of flammable liquids, gases or dust. Power tools create sparks which may ignite the dust or fumes.
3. Keep children and bystanders away while operating a power tool. Distractions can cause you to lose control.

ELECTRICAL SAFETY

1. Power tool plugs must match the outlet. Never modify the plug in any way. DO NOT use any adapter plugs with earthed (grounded) power tools. Unmodified plugs and matching outlets will reduce risk of electric shock.
2. Avoid body contact with earthed or grounded surfaces such as pipes, radiators, ranges, and refrigerators. There is an increased risk of electric shock if your body is earthed or grounded.
3. DO NOT expose power tools to rain or wet conditions. Water entering a power tool will increase the risk of electric shock.
4. DO NOT abuse the cord. Never use the cord for carrying, pulling or unplugging the power tool. Keep cord away from heat, oil, sharp edges or moving parts. Damaged or entangled cords increase the risk of electric shock.
5. When operating a power tool outdoors, use an extension cord suitable for outdoor use. Use of a cord suitable for outdoor use reduces the risk of electric shock.
6. If operating a power tool in a damp location is unavoidable, use a residual current device (RCD) protected supply. Use of a ground fault circuit interrupter (GFCI) reduces the risk of electric shock.

PERSONAL SAFETY

1. Stay alert, watch what you are doing, and use common sense when operating a power tool. DO NOT use a power tool while you are tired or under the influence of drugs, alcohol, or medication. A moment of inattention while operating power tools may result in serious personal injury.
2. Use personal protective equipment. Always wear eye protection. Protective equipment such as dust mask, non-skid safety shoes, hard hat, or hearing protection used for appropriate conditions will reduce personal injuries.
3. Prevent unintentional starting. Ensure the switch is in the OFF position before connecting to power source and/or battery pack, picking up or carrying the tool. Carrying power tools with your finger on the switch or energizing power tools that have the switch ON invites accidents.
4. Remove any adjusting key or wrench before turning the power tool on. A wrench or a key left attached to a rotating part of the power tool may result in personal injury.
5. DO NOT overreach. Keep proper footing and balance at all times. This enables better control of the power tool in unexpected situations.
6. Dress properly. DO NOT wear loose clothing or jewelry. Keep your hair, clothing, and gloves away from moving parts. Loose clothes, jewelry, or long hair can be caught in moving parts.
7. If devices are provided for the connection of dust extraction and collection facilities, ensure these are connected and properly used. Use of dust collection can reduce dust related hazards.

POWER TOOL SAFETY

1. DO NOT force the power tool. Use the correct power tool for your application. The correct power tool will do the job better and safer at the rate for which it was designed.
2. DO NOT use the power tool if the switch does not turn it ON and OFF. Any power tool that cannot be controlled with the switch is dangerous and must be repaired.
3. Disconnect the plug from the power source and/or the battery pack from the power tool before making any adjustments, changing accessories, or storing power tools. Such preventive safety measures reduce the risk of starting the power tool accidentally.

4. Store idle power tools out of the reach of children and DO NOT allow persons unfamiliar with the power tool or these instructions to operate the power tool. Power tools are dangerous in the hands of untrained users.
5. Maintain power tools. Check for misalignment or binding of moving parts, breakage of parts and any other condition that may affect the power tool's operation. If damaged, have the power tool repaired before use. Many accidents are caused by poorly maintained power tools.
6. Keep cutting tools sharp and clean. Properly maintained cutting tools with sharp cutting edges are less likely to bind and are easier to control.
7. Use the power tool, accessories and tool bits, etc. in accordance with these instructions, taking into account the working conditions and the work to be performed. Use of the power tool for operations different from those intended could result in a hazardous situation.
8. Hold power tool by insulated gripping surfaces, when performing an operation where the fastener may contact hidden wiring or its own cord. Fasteners contacting a "live" wire may make exposed metal parts of the power tool "live" and could give the operator an electric shock.

BATTERY TOOL USE AND CARE

1. Recharge only with the charger specified by the manufacturer. A charger that is suitable for one type of battery pack may create a risk of fire when used with another battery pack.
2. Use power tools only with specifically designated battery packs. Use of any other battery packs may create a risk of injury and fire.
3. When battery pack is not in use, keep it away from other metal objects, like paper clips, coins, keys, nails, screws, or other small metal objects that can make a connection from one terminal to another. Shorting the battery terminals together may cause burns or a fire.
4. Under abusive conditions, liquid may be ejected from the battery; avoid contact. If contact accidentally occurs, flush with water. If liquid contacts eyes, additionally seek medical help. Liquid ejected from the battery may cause irritation or burns.

SERVICE

Have your power tool serviced by a qualified repair person using only identical replacement parts. This will ensure that the safety of the power tool is maintained.

⚠WARNING:

SPECIFIC SAFETY RULES

1. Know your cordless Impact wrench. DO NOT plug in the charger or install the battery in the tool until you have read and understand this Instruction Manual. Learn the tool's applications and limitations, as well as the specific potential hazards related to this tool. Following this rule will reduce the risk of electric shock, fire, or serious injury.
2. Always wear eye protection. Any power tool can throw foreign objects into your eyes and cause permanent eye damage. ALWAYS wear safety goggles (not glasses) that comply with ANSI safety standard Z87.1. Everyday glasses have only impact resistant lenses. They ARE NOT safety glasses.
3. Glasses or goggles not in compliance with ANSI Z87.1 could cause serious injury when they break.
4. Always use hearing protection when operating the Impact Wrench.
5. Use only impact sockets and accessories that are designed for use with an Impact Wrench. DO NOT use chrome plated sockets and accessories. Chrome plated sockets and accessories are designed for hand use only and MUST NOT be used with an Impact Wrench. They may shatter and possibly cause serious injury.
6. Before each use, check the Impact sockets and accessories for excessive wear or cracks. Worn or damaged sockets or accessories may shatter and possibly cause serious injury. Worn accessories may allow the socket to come off during operation of the Impact Wrench.
7. After installing any accessory on the square drive, pull outward on the accessory to ensure it is properly installed.
8. Never use the Impact Wrench as a torque wrench. Always use a torque wrench to adjust the fastener to the specified torque.
9. Keep the Impact Wrench handle and body clean and free of oil and grease. Always use a clean dry cloth when cleaning. DO NOT use

OEMTOOLS™ 20V MAX* LITHIUM-ION 3/8" DRIVE CORDLESS IMPACT WRENCH

solvents, brake fluid, gasoline or other petroleum products to clean the tool. They will damage the tool.

10. DO NOT wear neckties or loose clothing.
11. When wearing gloves, they must be tight fitting and slip resistant type. Leather gloves offer the best protection.
12. Always use two hands when operating the Impact Wrench. Use one hand on the handle and the other on the front of the tool body.
13. Never place your hand so it is touching the socket or accessory when the tool is turned ON. Your hand could be seriously injured.
14. Always remove the battery from the tool before installing or removing any socket or accessory.
15. Be ready for components to shift when removing any fastener. The speed of the fastener removal could cause unexpected shifting of the components.

IMPORTANT SAFETY INSTRUCTIONS

The warnings, precautions, and instructions discussed in this manual cannot cover all possible conditions and situations that may occur. The operator must understand that common sense and caution are factors which cannot be built into this product, but must be supplied by the operator.

▲WARNING: Use only attachments recommended or sold by manufacturer.

1. DO NOT disassemble the Impact Wrench. Take it to a qualified professional when service or repair is required. Incorrect reassembly may result in electric shock or fire.
2. Only use impact sockets which are specifically designed for use with an Impact Wrench.
3. Wear approved safety eye/face shield, ear defenders and hand protection.

DISPOSAL

At the end of the useful life of the OEMTOOLS™ Impact Wrench, dispose of the components according to all state, federal and local regulations.

BATTERY DISPOSAL

Exposure to high temperatures can cause the batteries to explode; DO NOT dispose of in a fire. Some countries have regulations concerning battery disposal. Follow all applicable regulations. Return used batteries to a collection location for recycling. Call 800-822-8837 or visit www.call2recycle.org to find a collection location.

PURPOSE

The OEMTOOLS™ 20V Max* Lithium-Ion 3/8" Drive Cordless Impact Wrench is used for tightening or loosening nuts and bolts, automotive repair, body shop maintenance and other applications.

PRODUCT SPECIFICATIONS

Anvil:	3/8" Square Drive
Speed:	0-2,400 RPM; 0-3,000 IPM
Max. Tightening Torque:	200 Ft/Lbs.
Nut Busting Torque:	240 Ft/Lbs.
Battery:	20V, 1.5 Ah Li-ion
Weight:	2.1 Lbs.
Charge Time:	3-5 Hrs.

INSTRUCTIONS

Always wear safety goggles and gloves.

1. If removing wheels from a vehicle, block the wheels and jack the car as instructed in the owner's manual.
2. In other applications, be ready for parts shifting when the fastener is removed.
3. Install the correct impact socket on the tool. Only use impact rated sockets.
4. Select the correct rotation direction using the button above the trigger switch.
5. Slide the fully charged battery pack onto the base of the handle. The tool will operate at peak power with a fully charged battery pack.
6. Place the socket onto the fastener to be removed/tightened.
7. Hold the Impact Wrench with both hands and squeeze the trigger to start the tool. The tool is variable speed so the harder you squeeze the higher the speed.

8. When removing nuts, always squeeze the trigger fully so the tool operates at its maximum speed to generate maximum torque.
9. If a fastener to be removed is "frozen" and will not loosen after 15 seconds of operation, reverse the Impact Wrench rotation and tighten the fastener for 5 seconds to break it loose then change the rotation direction again to remove the fastener.
10. When tightening fasteners, DO NOT let the tool "rattle" for more than 2-3 seconds. This may overtighten the fastener.
11. Always check tightened fasteners with a torque wrench recommended by the manufacturer to ensure the correct torque has been applied. Particularly when tightening wheel nuts.

▲WARNING: Always charge the battery pack indoors in a well-ventilated area. The charger must never be subjected to wet conditions.

▲ELECTRICAL WARNING:

POWER SOURCE CONNECTION POWER REQUIREMENTS

This product is designed to operate on a properly grounded 120 volt, 60Hz, single-phase alternating current (AC) power source fused with a time delayed fuse or circuit breaker. It is recommended that a qualified electrician verify the ACTUAL VOLTAGE at the receptacle into which the product will be plugged and confirm that the receptacle is properly fused and grounded.

DO NOT OPERATE THIS PRODUCT if the ACTUAL power source voltage is less than 105 Volts AC or greater than 132 Volts AC. Contact a qualified electrician if this problem exists. Improper performance and/or damage to the product will result if operated on inadequate or excessive power. DO NOT abuse cord. Never use the cord to carry tools or pull the plug from an outlet. Keep cord away from heat, sharp edges or moving parts. Replace damaged cords immediately. Damaged cords increase the risk of electric shock.

CHARGING THE BATTERY PACK:

1. Place the discharged battery in a dry location near a 110-120V 60 Hz electrical outlet.
 2. Slide the battery charging cap onto the battery.
- NOTE:** Make sure the keys in the sides of the battery slide into the matching grooves in the charging cap. Slide the charging cap as far as it will go onto the battery.
3. Insert the transformer plug into the charging cap.
 4. Plug the transformer into the 110-120V 60 Hz wall receptacle.

BATTERY INDICATOR LIGHTS

1. The red indicator light will turn ON indicating the charger is "live."
2. The green and red indicator lights will turn ON when the charging cap is properly installed onto the battery.
3. If the indicator lights do not turn on, check to make sure the charging cap is slid fully onto the battery and the electrical outlet is working properly.
4. The green indicator light will turn ON when the battery is fully charged.
5. The battery should be left on the charger for 5 hours or until the green indicator light turns ON to ensure it is fully charged.
6. It is normal for the battery charger to hum and be warm to the touch during operation.
7. If the battery pack does not charge properly, check to make sure the electrical outlet is "live."
8. DO NOT charge batteries when the work area or the battery temperature is at or below 32°F (0°C) or above 113°F (45°C).

Green Light	Red Light	Battery on the Charger	Charging Status
OFF	ON	NO	Charger connected to the power supply
ON	ON	YES	Battery charging
ON	OFF	YES	Battery fully charged

OEMTOOLS™ 20V MAX* LITHIUM-ION 3/8" DRIVE CORDLESS IMPACT WRENCH

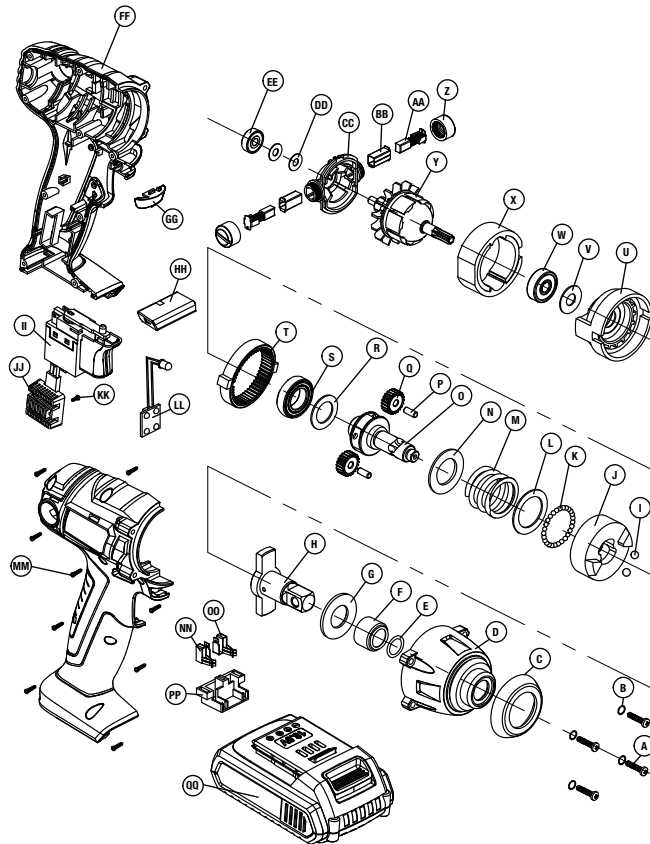

Figure	Description	Qty.
A	Screws	4
B	Spring Washer	4
C	Rubber Sleeve	1
D	Front Housing	1
E	O-Ring	1
F	Bushing	1
G	Washer	1
H	Anvil	1
I	Ball	2
J	Impact Block	1
K	Bearing	1
L	Washer	1
M	Spring	1
N	Washer	1
O	Inner Shaft	1
P	Pin	2
Q	Planetary Gear	1
R	Washer	1
S	Bearing	1
T	Ring Gear	1
U	Gear Box	1
V	Washer	1
W	Bearing	1
X	Stator	1
Y	Rotor	1
Z	Brush Cap	2

Figure	Description	Qty.
AA	Brush	2
BB	Brush Holder	2
CC	Commutator	1
DD	Washer	2
EE	Bearing	1
FF	Handle Assembly	1
GG	LED Cover	1
HH	Direction Setting Button	1
II	Trigger	1
JJ	Enclosure	1
KK	Hook	1
LL	LED Circuit Board	1
MM	Screw	9
NN	Contactor	1
OO	Contactor	1
PP	Contactor Housing	1
QQ	Battery	1

NOTE: Not all components of the Impact Wrench are replacement items, but are illustrated as a convenient reference for location and position in the assembly sequence.



This symbol designates that this tool is listed with Intertek 3042597 U.S. requirements by ETL Testing Laboratories, Inc. and conforms to UL Std. 60745-1 and 60745-2-2. JD508120

OEMTOOLS™ One Year Warranty

For up to one year from the date of purchase of this OEMTOOLS™ product, if you find any defect in material or workmanship (through normal usage), return it to the place of purchase or to OEMTOOLS™ for repair or replacement at our discretion. In order to obtain this service, send the product and proof of purchase (transportation pre-paid) to:

OEMTOOLS™ Q.A. Dept, 3580 E. Raines Road #3, Memphis, TN 38118.

We will not be responsible for lost or damaged goods during transportation; please insure your package. If our inspection verifies the defect, we will either repair or replace the product, or we may elect to refund the purchase price if we cannot readily and quickly provide you with a replacement. We will return repaired products at our expense, but if we determine there is no defect, or that the defect resulted from causes not within the scope of our warranty, then you must bear the cost of returning the product.

OEMTOOLS™ does not provide warranty for products labeled other than OEM® or OEMTOOLS™. OEMTOOLS™ will not provide any warranty for products subjected to abnormal use. Abnormal use includes (but is not limited to) abuse, accident, alteration, neglect, and unauthorized or unreasonable use or repairs. This warranty does not cover bits, blades, files, batteries, or calibration. We recommend that you maintain your tools and sharpen or replace blades, bits, files, and batteries as necessary. OEMTOOLS™ reserves the right to make any changes in construction or design at any time without any obligation in incorporating such changes to tools or equipment previously sold. OEMTOOLS™ makes every effort to ensure that its products meet high quality and durability standards, and warrants to the original purchaser that this product is free from defects in materials and workmanship for the period of one year from the date of purchase. This warranty does not apply to damage due directly or indirectly to misuse, abuse, negligence or accidents, repairs or alterations outside our facilities, criminal activity, improper installation, normal wear and tear or to lack of maintenance.

We shall in no event be liable for death, injuries to persons or property, or for incidental, contingent, special or consequential damages arising from the use of our product. Some states do not allow the exclusion or limitation of incidental or consequential damages, so the above limitation of exclusion may not apply to you. THIS WARRANTY IS EXPRESSLY IN LIEU OF ALL OTHER WARRANTIES, EXPRESS OR IMPLIED, INCLUDING THE WARRANTIES OF MERCHANTABILITY AND FITNESS. This warranty gives you specific legal rights, and you may also have other rights, which vary from state to state.

Don't forget to register your new OEMTOOLS™ product at www.oem-tools.com.

CONTACT US

3580 E. Raines Road, Suite 3, Memphis, TN 38118
 Tel: 1-866-458-2472
www.oem-tools.com