

Please read and save these instructions. Read through this owner's manual carefully before using product. Protect yourself and others by observing all safety information, warnings, and cautions. Failure to comply with instructions could result in personal injury and/or damage to product or property. Please retain instructions for future reference.



20V MAX* LI-ION RECIPROCATING SAW

FOR CUSTOMER SERVICE

Technical Question?

CALL 1-866-458-2472
customerservice@oem-tools.com

UNPACKING

After unpacking unit, inspect carefully for any damage that may have occurred during transit. Check for loose, missing, or damaged parts. If any damage is observed, a shipping damage claim must be filed with carrier. DO NOT use the OEMTOOLS® Reciprocating Saw if broken, bent, cracked or damaged parts (including labels) are noted. Any Reciprocating Saw that appears damaged in any way, operates abnormally or is missing parts should be removed from service immediately. If you suspect that the Reciprocating Saw was subjected to shock load (a load that was dropped suddenly, unexpectedly, etc.) immediately discontinue use until it has been checked by a factory authorized service center.



*Voltage is measured without workload. Maximum initial battery voltage after charging. Nominal voltage is 18 Volts.

⚠ WARNING

The following safety information is provided as a guideline to help you operate your Reciprocating Saw under the safest possible conditions. Any tool or piece of equipment can be potentially dangerous to use when safety or safe handling instructions are not known or not followed. The following safety instructions are to provide the user with the information necessary for safe use and operation. Please read and retain these instructions for the continued safe use of your service system. Failure to follow instructions listed below may result in serious injury. In addition, make certain that anyone who uses the equipment understands and follows these safety instructions as well.

Explanation of Safety Signal Words

⚠ WARNING: Indicates a potentially hazardous situation which, if not avoided, could result in death or serious injury.

⚠ CAUTION: Indicates a potentially hazardous situation which, if not avoided, may result in minor or moderate injury.

CAUTION: Used without the safety alert symbol indicates a potentially hazardous situation which, if not avoided, may result in property damage.

NOTES: Provide clarity and helpful information.

Thank you very much for choosing an OEMTOOLS® Product!

For future reference, please register your new tool at www.oem-tools.com and complete the owner's record below:

Model: _____ **Purchase Date:** _____

Save the receipt, warranty and these instructions. It is important that you read the entire manual to become familiar with this product before you begin using it. This product is designed for certain applications only. OEMTOOLS® cannot be responsible for issues arising from modification. We strongly recommend this product is not modified and/or used for any application other than that for which it was designed. If you have any questions relative to a particular application, DO NOT use the product until you have first contacted customer service to determine if it can or should be performed on the product.

⚠ WARNING: This product can expose you to chemicals, including acrylonitrile, which are known to the State of California to cause cancer and birth defects or other reproductive harm. For more information, go to www.P65Warnings.ca.gov.



20V MAX* LI-ION RECIPROCATING SAW

POWER TOOL SAFETY

⚠ WARNING

Read and understand all safety warnings and instructions. Failure to follow the warnings and instructions may result in electric shock, fire and/or serious injury.

Save all warnings and instructions for future reference.

WORK AREA SAFETY

1. Keep work area clean and well lit. Cluttered or dark areas invite accidents.
2. DO NOT operate power tools in explosive atmospheres, such as in the presence of flammable liquids, gases or dust. Power tools create sparks which may ignite the dust or fumes.
3. Keep children and bystanders away while operating a power tool. Distractions can cause you to lose control.

ELECTRICAL SAFETY

1. Power tool plugs must match the outlet. Never modify the plug in any way. DO NOT use any adapter plugs with earthed (grounded) power tools. Unmodified plugs and matching outlets will reduce risk of electric shock.
2. Avoid body contact with earthed or grounded surfaces such as pipes, radiators, ranges and refrigerators. There is an increased risk of electric shock if your body is earthed or grounded.
3. DO NOT expose power tools to rain or wet conditions. Water entering a power tool will increase the risk of electric shock.
4. DO NOT abuse the cord. Never use the cord for carrying, pulling or unplugging the power tool. Keep cord away from heat, oil, sharp edges or moving parts. Damaged or entangled cords increase the risk of electric shock.
5. When operating a power tool outdoors, use an extension cord suitable for outdoor use. Use of a cord suitable for outdoor use reduces the risk of electric shock.
6. If operating a power tool in a damp location is unavoidable, use a residual current device (RCD) protected supply. Use of a ground fault circuit interrupter (GFCI) reduces the risk of electric shock.

PERSONAL SAFETY

1. Stay alert, watch what you are doing and use common sense when operating a power tool. DO NOT use a power tool while you are tired or under the influence of drugs, alcohol or medication. A moment of inattention while operating power tools may result in serious personal injury.
2. Use personal protective equipment. Always wear eye protection. Protective equipment such as dust mask, non-skid safety shoes, hard hat, or hearing protection used for appropriate conditions will reduce personal injuries.
3. Prevent unintentional starting. Ensure the switch is in the off-position before connecting to power source and/or battery pack, picking up or carrying the tool. Carrying power tools with your finger on the switch or energizing power tools that have the switch on invites accidents.
4. Remove any adjusting key or wrench before turning the power tool on. A wrench or a key left attached to a rotating part of the power tool may result in personal injury.

5. DO NOT overreach. Keep proper footing and balance at all times. This enables better control of the power tool in unexpected situations.
6. Dress properly. DO NOT wear loose clothing or jewelry. Keep your hair, clothing and gloves away from moving parts. Loose clothes, jewelry or long hair can be caught in moving parts.
7. If devices are provided for the connection of dust extraction and collection facilities, ensure these are connected and properly used. Use of dust collection can reduce dust related hazards.

POWER TOOL SAFETY

1. DO NOT force the power tool. Use the correct power tool for your application. The correct power tool will do the job better and safer at the rate for which it was designed.
2. DO NOT use the power tool if the switch does not turn it on and off. Any power tool that cannot be controlled with the switch is dangerous and must be repaired.
3. Disconnect the plug from the power source and/or the battery pack from the power tool before making any adjustments, changing accessories, or storing power tools. Such preventive safety measures reduce the risk of starting the power tool accidentally.
4. Store idle power tools out of the reach of children and do not allow persons unfamiliar with the power tool or these instructions to operate the power tool. Power tools are dangerous in the hands of untrained users.
5. Maintain power tools. Check for misalignment or binding of moving parts, breakage of parts and any other condition that may affect the power tool's operation. If damaged, have the power tool repaired before use. Many accidents are caused by poorly maintained power tools.
6. Keep cutting tools sharp and clean. Properly maintained cutting tools with sharp cutting edges are less likely to bind and are easier to control.
7. Use the power tool, accessories and tool bits etc. in accordance with these instructions, taking into account the working conditions and the work to be performed. Use of the power tool for operations different from those intended could result in a hazardous situation.
8. Hold the power tool by insulated gripping surfaces when performing an operation where the cutting tool may contact hidden wiring or its own cord. Contact with a "live" wire will make exposed metal parts of the tool "live" and shock the operator.
9. Use clamps or other practical ways to secure and support the workpiece to a stable platform. Holding the workpiece by hand or against your body leaves it unstable and may lead to loss of control.

BATTERY TOOL USE AND CARE

1. Recharge only with the charger specified by the manufacturer. A charger that is suitable for one type of battery pack may create a risk of fire when used with another battery pack.
2. Use power tools only with specifically designated battery packs. Use of any other battery packs may create a risk of injury and fire.



20V MAX* LI-ION RECIPROCATING SAW

- When the battery pack is not in use, keep it away from other metal objects, like paper clips, coins, keys, nails, screws or other small metal objects that can make a connection from one terminal to another. Shorting the battery terminals together may cause burns or a fire.
- Under abusive conditions, liquid may be ejected from the battery; avoid contact. If contact accidentally occurs, flush with water. If liquid contacts eyes, additionally seek medical help. Liquid ejected from the battery may cause irritation or burns.

SERVICE

Have your power tool serviced by a qualified repair person using only identical replacement parts. This will ensure that the safety of the power tool is maintained.

SPECIFIC SAFETY RULES

⚠ WARNING

- Know your reciprocating saw. DO NOT plug the charger into the power source or install the battery in the tool until you have read and understand this Instruction Manual. Learn the tool's applications and limitations, as well as the specific potential hazards related to this tool. Following this rule will reduce the risk of electric shock, fire, or serious injury.
- Always wear eye protection. Any power tool can throw foreign objects into your eyes and cause permanent eye damage. ALWAYS wear safety goggles (not glasses) that comply with ANSI safety standard Z87.1. Everyday glasses have only impact resistant lenses. They ARE NOT safety glasses.
- Glasses or goggles not in compliance with ANSI Z87.1 could cause serious injury when they break. **WARNING!** Always use hearing protection when sawing, particularly during extended periods of operation.

⚠ WARNING

Always use hearing protection when sawing, particularly during extended periods of operation.

⚠ WARNING

Always remove the battery before changing the blade and when making any adjustments.

- DO NOT wear gloves, neckties or loose clothing.
- Hold the tool by its insulated gripping surfaces when performing an operation where the saw blade may contact hidden wiring or its own cord. Contact with a "live" wire will make exposed metal parts of the tool "live" and shock the operator.
- Always hold the tool with two hands. Attempting to control the tool with only one hand is dangerous. It could result in loss of control and serious injury.
- Never hold the workpiece in one hand and the tool in the other hand when sawing. Never place the hands near or below the cutting surface. Clamp the workpiece and guide the tool with both hands.
- Always make sure the work surface is free from nails and other foreign objects. Cutting into a nail can cause the blade and the tool to jump and damage the blade.
- Never lay the workpiece on hard surfaces like concrete, stone etc. The protruding blade may cause tool to jump.

- After changing a blade or making adjustments, make sure the blade clamp is holding the blade securely. Loose blades could be violently thrown from the tool.
- Never use dull or damaged blades. Sharp blades must be handled with care. Damaged blades can snap during use. Dull blades require more force to cut the workpiece, possibly causing the blade to break.
- Never touch the blade during or immediately after use. After use, the blade is too hot to be touched.

IMPORTANT SAFETY INSTRUCTIONS

The warnings, precautions, and instructions discussed in this manual cannot cover all possible conditions and situations that may occur. The operator must understand that common sense and caution are factors which cannot be built into this product, but must be supplied by the operator.

⚠ WARNING

Use only attachments recommended or sold by manufacturer.

- DO NOT disassemble the saw. Take it to a qualified professional when service or repair is required. Incorrect reassembly may result in electric shock or fire.
- Wear approved safety eye/face shield, ear defenders and hand protection.

DISPOSAL

At the end of the useful life of the OEMTOOLS® 20V MAX* Li-Ion Reciprocating Saw dispose of the components according to all state, federal and local regulations.

BATTERY DISPOSAL

Exposure to high temperatures can cause the batteries to explode; do not dispose of in a fire. Some countries have regulations concerning battery disposal. Follow all applicable regulations. Return used batteries to a collection location for recycling. Call 800-822-8837 or visit www.call2recycle.org to find a collection location.

PURPOSE

The OEMTOOLS® 20V Max* Lithium-Ion Reciprocating Saw is ideal for demolition and remodeling. Designed to cut through many types of materials such as wood, metal, PVC and nails..

PRODUCT SPECIFICATIONS

Voltage:	20V MAX*
Variable Speed:	0-3000 SPM
Stroke Length:	1"
Max. Cutting Capacity:	3-1/8" (wood with 12" blade)
Max. Cutting Capacity:	3/4" (pipe)
Overall Length:	14-1/4"
Electric Brake:	Yes
Battery:	2.0Ah Li-Ion
Charge Time:	1 Hr.
Weight:	7.29 Lbs.



20V MAX* LI-ION RECIPROCATING SAW

INSTRUCTIONS

Always wear safety goggles.

⚠ WARNING

DO NOT immerse the battery pack in water. Sudden cooling could cause a hot battery to explode or leak.

INSTALLING A BLADE

⚠ WARNING

Always remove the battery from the tool before installing or removing a blade or adjusting the saw in any way.

1. To install a blade in the saw, rotate the blade locking sleeve (1) counter clockwise (Fig. 1).

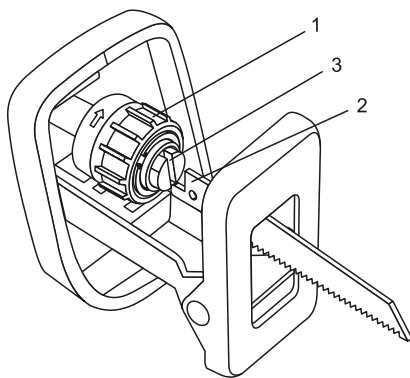

Figure 1

2. Insert the appropriate blade (2) into the blade slot (3) as far as it will go.
3. Release the blade locking sleeve.

NOTE: The blade will automatically be locked into the blade holder. Pull outward on the blade to ensure it is properly locked into the blade holder.

REMOVING A BLADE

To remove a blade, simply rotate the blade locking sleeve counter clockwise and remove the blade from the blade holder.

ADJUSTING THE PIVOTING SHOE

1. The pivoting shoe will pivot to follow the angle of the blade to the workpiece. This action ensures the flat surface of the shoe is against the workpiece for better cutting action and easier control of the saw.
2. The shoe can be adjusted in or out, allowing the use of the blade teeth at different points on the blade. This will provide longer blade life as one section of the blade becomes dull.
3. To adjust the pivoting shoe rotate the pivoting shoe adjusting lever to its downward position
4. Slide the pivoting shoe in or out until it is in the appropriate position.
5. Lock the pivoting shoe in place by rotating the pivoting shoe adjusting lever upward to its original horizontal position.
6. Pull outward on the pivoting shoe to ensure it is firmly locked in place.

LOCK-OUT SWITCH

1. The lock-out switch (1) is a safety device designed to reduce the possibility of a user accidentally starting the saw. (Figure 2)

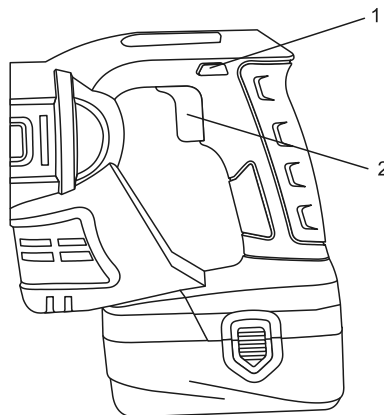

Figure 2

2. This switch must be pressed before the trigger (2) switch can be squeezed.

NOTE: The lock-out switch can be pressed from either the left or right side of the handle.

VARIABLE SPEED TRIGGER SWITCH

The trigger switch turns the reciprocating saw ON and OFF as well as controlling the speed.

1. To turn the saw ON, press the lock-out switch with your thumb. (Figure 2)

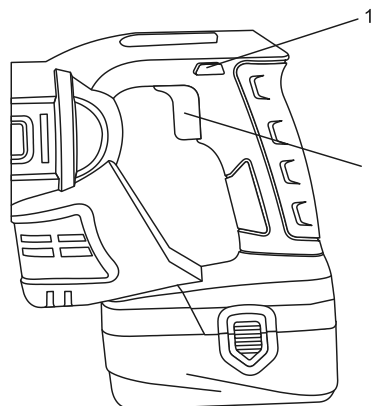

Figure 2

2. While holding the lock-out switch in the pressed position, squeeze the trigger (2) switch to start the saw.
3. Once the saw starts, release the lock-out switch. The saw will remain running until the trigger switch is released.

NOTE: The trigger switch also controls the speed at which the saw runs. The more you squeeze the trigger, the faster the saw will run.

4. To turn the saw OFF, release the trigger switch.

NOTE: To re-start the saw, the lock-out switch must be pressed again before the trigger switch is squeezed.



20V MAX* LI-ION RECIPROCATING SAW

MATERIALS YOU CAN CUT

This reciprocating saw is a versatile tool that allows you to cut many different types of materials. Some of these materials include:

- Wood products such as lumber, hardwood, plywood, composite board, and paneling
- Drywall
- Fiber board and plastic
- Metals, such as pipe, steel rods, sheet steel, aluminum, brass, and copper

NOTE: There are many different types of blades available. Generally, there are metal cutting blades (fine teeth) and wood cutting blades (coarse teeth). Use the correct blade for your application. The packaging on the blade will indicate the type of materials each blade is designed to cut.

GENERAL CUTTING

1. Clearly mark the workpiece to locate the position of the cut.
2. Hold smaller workpieces with a vice. Clamp larger workpieces to a workbench or table.

⚠ WARNING

Any workpiece that is not adequately clamped in place may come loose and cause serious injury. Never hold the workpiece with your hand.

3. Make sure there are no nails, screws, clamps or foreign materials in the path of the saw blade.
4. Hold the saw away from your body and in front of you.
5. With both hands firmly gripping the saw, and with the blade NOT in contact with the surface to be cut, start the saw by pressing the lock-out switch and squeezing the trigger switch.
6. Once the saw has reached the desired speed, place the adjustable pivoting shoe against the workpiece and gradually bring the moving blade into contact with the workpiece at the appropriate location.

⚠ CAUTION

DO NOT force the saw. Use only enough force to keep the blade cutting. Excessive pressure on the blade will cause it to bend and twist, which may result in breaking the blade.

PLUNGE CUTTING

1. Clearly mark the workpiece to locate the position of the cut.
2. Clamp the workpiece to a workbench or table.

NOTE: Make sure the area to be cut is clear under the workpiece so that the blade will not come into contact with anything other than the workpiece.

3. Select a convenient starting point in the area to be cut out. Place the tip of the blade over that point.
4. Rest the lower edge of the adjustable pivoting shoe on the workpiece and hold it firmly in that position, maintaining a shallow cutting angle.
5. Press the lock-out switch and squeeze the trigger switch to start the saw.

⚠ WARNING

Make sure the blade does not touch the workpiece until the saw reaches full speed. Loss of control and possible injury could result.

6. With the saw running at full speed, slowly tilt the saw until the tip of the blade contacts the workpiece and begins to cut. After the blade cuts through the workpiece, tilt the saw upward until the blade is perpendicular to the workpiece.

METAL CUTTING

1. Metals such as pipe, steel rods, sheet steel, aluminum, brass and copper can be cut with your reciprocating saw
2. To cut thin sheet material, “sandwich” the material between hardboard or plywood and clamp the layers to limit vibration and material tearing.
3. Always use a fine toothed metal cutting blade and run the saw at medium speeds when cutting metal.
4. Use cutting oil to keep the blade cool, increase cutting action, and prolong the life of the blade.
5. DO NOT twist or bend the saw blade.
6. DO NOT force the saw blade. Let it cut at its own speed.

⚠ WARNING

Always clamp the workpiece in a vice, or to a workbench or table. DO NOT hold workpiece in your hand. Never use gasoline as a lubricant or as a cleaning agent. A spark from the motor may cause an explosion. Gasoline will also damage the plastic components of the saw.

MAINTENANCE

⚠ WARNING

When servicing, use only identical replacement parts. The use of any other part may create a hazard or cause product damage.

DO NOT use solvents when cleaning plastic parts. Plastics are susceptible to damage from various types of commercial solvents and may be damaged by their use. Use a clean cloth to remove dirt, dust, oil, grease etc.

⚠ WARNING

DO NOT allow brake fluids, gasoline, petroleum-based products, penetrating oils, etc. to come into contact with plastic parts. They contain chemicals that can damage, weaken or destroy plastic.

DO NOT abuse power tools. Abusive practices can damage the tool and the workpiece.

⚠ WARNING

DO NOT attempt to modify tools or create accessories. Any such alteration or modification is misuse and could result in a hazardous condition leading to possible serious injury. It will also void the warranty.



20V MAX* LI-ION RECIPROCATING SAW

NOTE: It has been found that electric tools are subjected to accelerated wear and possible premature failure when they are used on fiberglass boats and sports cars, wallboard, spackling compounds or plaster. The chips and grindings from these materials are highly abrasive to electric tool parts such as bearings, brushes, commutators, etc. Consequently, it is not recommended that this tool be used for extended work on any fiberglass material, wallboard, spackling compounds or plaster. During any use on these materials it is extremely important that the tool is cleaned frequently by blowing it out with an air jet.

LUBRICATION

All of the bearings in this tool are lubricated with a sufficient amount of high-grade lubricant for the life of the unit under normal conditions. Therefore, no further lubrication is required.

WARNING

Always charge the battery pack indoors in a well-ventilated area. The charger must never be subjected to wet conditions.

ELECTRICAL WARNING

POWER SOURCE CONNECTION POWER REQUIREMENTS

This product is designed to operate on a properly grounded 120 volt, 60Hz, single-phase alternating current (AC) power source fused with a time delayed fuse or circuit breaker. It is recommended that a qualified electrician verify the ACTUAL VOLTAGE at the receptacle into which the product will be plugged and confirm that the receptacle is properly fused and grounded.

DO NOT OPERATE THIS PRODUCT if the ACTUAL power source voltage is less than 105 Volts AC or greater than 132 Volts AC. Contact a qualified electrician if this problem exists. Improper performance and/or damage to the product will result if operated on inadequate or excessive power.

DO NOT abuse cord. Never use the cord to carry tools or pull the plug from an outlet. Keep cord away from heat, sharp edges or moving parts. Replace damaged cords immediately. Damaged cords increase the risk of electric shock.

CHARGING THE BATTERY PACK:

1. Place the charger in a dry location near a 120V/60 Hz electrical outlet.
2. Plug the charger into the electrical outlet.
3. The green LED light will turn on.
4. Turn the battery pack upside down and slide it onto the charger.
5. The green LED light will turn off and the red LED light will begin to flash indicating the battery pack is charging.
6. The red LED light will turn off and the green LED light will turn on when fully charged.
7. Once the battery pack is fully charged, remove the charger plug from the power source and remove the battery pack from the charger.

NOTE: DO NOT charge batteries when the work area or the battery temperature is at or below 32° F (0° C) or above 113° F (45° C).

Green Light	Red Light	Battery on the Charger	Charging Status
ON	OFF	NO	Charger connected to power supply
OFF	FLASHING	YES	Battery charging
ON	OFF	YES	Battery fully charged
OFF	ON	YES	Battery defective or bad contact
ON	ON	YES	Battery too hot or too cold to be charged



20V MAX* LI-ION RECIPROCATING SAW

Parts List

Figure	Description	Qty.
A	Housing	1
B	Quick Release Wrench	1
C	Wrench Insert	1
D	Gear Box Pressure Plate	1
E	Gear Pressure Plate	1
F	Shaft Sleeve	1
G	Spindle	1
H	Hex Screw	4
I	Bearing Seat Cover	1
J	Reciprocating Rod Bearing	1
K	Wool Felt Folder	1
L	Gear	1
M	Deep Groove Ball Bearing	2
N	Front Shock Pad	2
O	Rear Shock Absorber	2
P	Switch Lock Lever	1
Q	Switch Lock Lever Spring	1
R	Motor	1
S	Motor Positioning Board	1
T	Pan Head Screw	3
U	Flat Head Screw	7
V	Bearing Plate	1

Figure	Description	Qty.
W	Elastic Snap Ring	1
X	Motor Gear	1
Y	Deep Groove Ball Bearing	1
Z	Flat Washer	1
AA	Plate Shrapnel	1
BB	Bottom Plate	1
CC	Elastic Snap Ring	1
DD	Gear Box	1
EE	Reciprocating Rod	1
FF	Sheep Felt	1
GG	Reciprocating Rod Assembly	1
HH	Floor Support	1
II	Bottom Plate	1
JJ	Screw	8
KK	Screw	4
LL	Switch Button	1
MM	Switch	1
NN	Zinc-Plated Hex Screw	1
OO	Cooling Block	1
PP	Electrode Plate	1
QQ	Battery	1

Parts Diagram

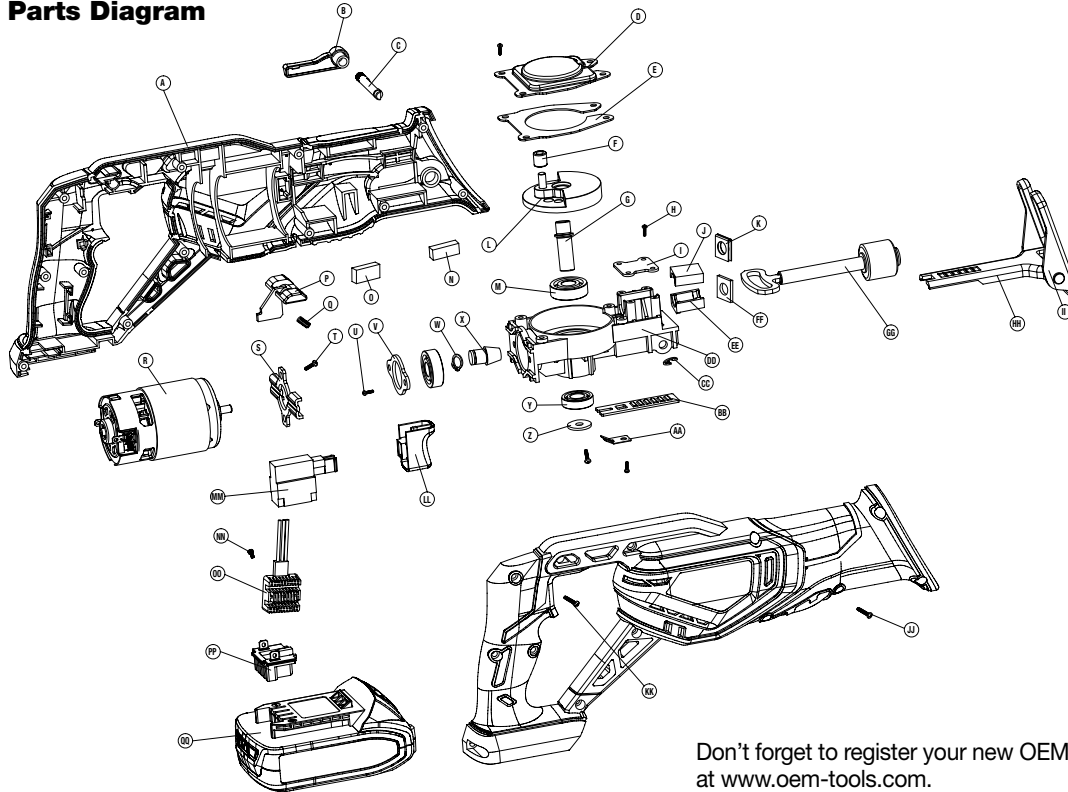

Don't forget to register your new OEMTOOLS® product at www.oem-tools.com.

NOTE:

Not all components of the Reciprocating Saw are replacement items, but are illustrated as a convenient reference for location and position in the assembly sequence.



Intertek
3042597
JD5218

This symbol designates that this tool is listed with U.S. requirements by ETL Testing Laboratories, Inc. Conforms to UL Std. 60745-1 and 60745-2-2.





20V MAX* LI-ION RECIPROCATING SAW

OEMTOOLS® ONE YEAR WARRANTY

If for up to one year from the date of purchase of this OEMTOOLS® product you find any defect in material or workmanship, through normal usage, return it to the place of purchase, or to OEMTOOLS® for repair or replacement at our discretion. In order to obtain this service, send your tool and proof of purchase, transportation pre-paid, to OEMTOOLS® Q.A. Dept., 3580 E. Raines Road #3, Memphis, TN 38118. We will not be responsible for lost or damaged goods during transportation; please insure your package. If our inspection verifies the defect, we will either repair or replace the product at our election, or we may elect to refund the purchase price if we cannot readily and quickly provide you with a replacement. We will return repaired products at our expense, but if we determine there is no defect, or that the defect resulted from causes not within the scope of our warranty, then you must bear the cost of returning the product.

OEMTOOLS® does not provide warranty for products labeled other than OEM® or OEMTOOLS®. OEMTOOLS® will not provide any warranty for products subjected to abnormal use. Abnormal use includes, but is not limited to, abuse, accident, alteration, neglect, and unauthorized or unreasonable use or repairs. This warranty does not cover bits, blades, files, batteries, or calibration. We recommend that you maintain your tools and sharpen or replace blades, bits, files, and batteries as necessary. OEMTOOLS® reserves the right to make any changes in construction or design at any time without any obligation in incorporating such changes to tools or equipment previously sold.

OEMTOOLS® makes every effort to ensure that its products meet high quality and durability standards, and warrants to the original purchaser that this product is free from defects in materials and workmanship for the period of one year from the date of purchase. This warranty does not apply to damage due directly or indirectly to misuse, abuse, negligence or accidents, repairs or alterations outside our facilities, criminal activity, improper installation, normal wear and tear or to lack of maintenance.

We shall in no event be liable for death, injuries to persons or property, or for incidental, contingent, special or consequential damages arising from the use of our product. Some states do not allow the exclusion or limitation of incidental or consequential damages, so the above limitation of exclusion may not apply to you. THIS WARRANTY IS EXPRESSLY IN LIEU OF ALL OTHER WARRANTIES, EXPRESS OR IMPLIED, INCLUDING THE WARRANTIES OF MERCHANTABILITY AND FITNESS. This warranty gives you specific legal rights, and you may also have other rights, which vary from state to state.

CONTACT US

3580 E. Raines Road, Suite 3, Memphis, TN 38118
Tel: 1-866-458-2472
www.oem-tools.com